

Section 10

WHAT ARE ELECTRIC FIELDS? DO THEY STORE ENERGY?

INTRODUCTION

In a previous section we saw an acrylic plate with excess (+) charge cause charge flow through a neon bulb from one nearby metal plate to another metal plate located farther away. Bulb lighting was evidence that a “potential pressure halo” around the excess (+) charge on the acrylic raised the pressure in the nearer metal plate higher than in the farther plate. Mobile charge was made to move through the bulb by

- pressure difference in the plates that provided pushing strength.
- HIGH → LOW pressure gradient that showed pushing direction.

We also saw the acrylic’s excess (+) charge repel mobile tapes charged (+) and attract mobile tapes charged (-). Note the difference: These tapes are not pushed by different pressures, produced in different pieces of metal by a halo around the charge on the acrylic. Rather, the charged tapes are pushed directly by the charged acrylic. This situation suggests the tapes are pushed by a previously new causal agent that exists – together with electric potential – in the halo around the charge on the acrylic. To search for hard evidence for a direct charge-pushing agent in the space around charge accumulations, we begin this section by identifying the conditions required to make sparks jump through the air between two conductors charged (+) and (-).

Creating a spark requires a causal agent that pushes (+) and (-) parts of atoms directly and in opposite directions – an action leading to the separation of these parts (ionization). We will give this direct causal agent the name “electric field”. To account for the direction and strength of the forces it exerts, an electric field must have a direction and a strength at every space point. The property of the electric field that specifies the field’s direction and strength at any given space point will be called an “electric vector”. Try to visualize electric vectors in space near (+) charge or (-) charge as being like flow vectors in bathwater near a faucet (flow vectors point out) or a drain (flow vectors point in).

Useful analog imagery might be accessed in class discussion of properties that vary from point to point in various “extended things in space”. Some examples are:

<u>Extended Thing</u>	<u>Point Property</u>	<u>Character</u>
Cloud	Vapor density	Number
Flame	Temperature	Number
Balloon	Air pressure	Number
Tornado	Wind velocity	Vector

INVESTIGATION ONE: WHAT IS THE CONDITION THAT MAKES A SPARK JUMP?

10.1 Activity: Experimenting with the pie plate capacitor – review and extension

You have seen in Section 8 how the behavior of a pie plate capacitor can be explained by the idea of a halo of potential pressure in the space around a charged object. Figure 10.1a shows the pie plate capacitor with a neon bulb and a charged negative foam plate near it. We can represent this arrangement with a simpler diagram shown at the right, which shows the two neutral pie plates and negatively charged foam plate in cross-section.

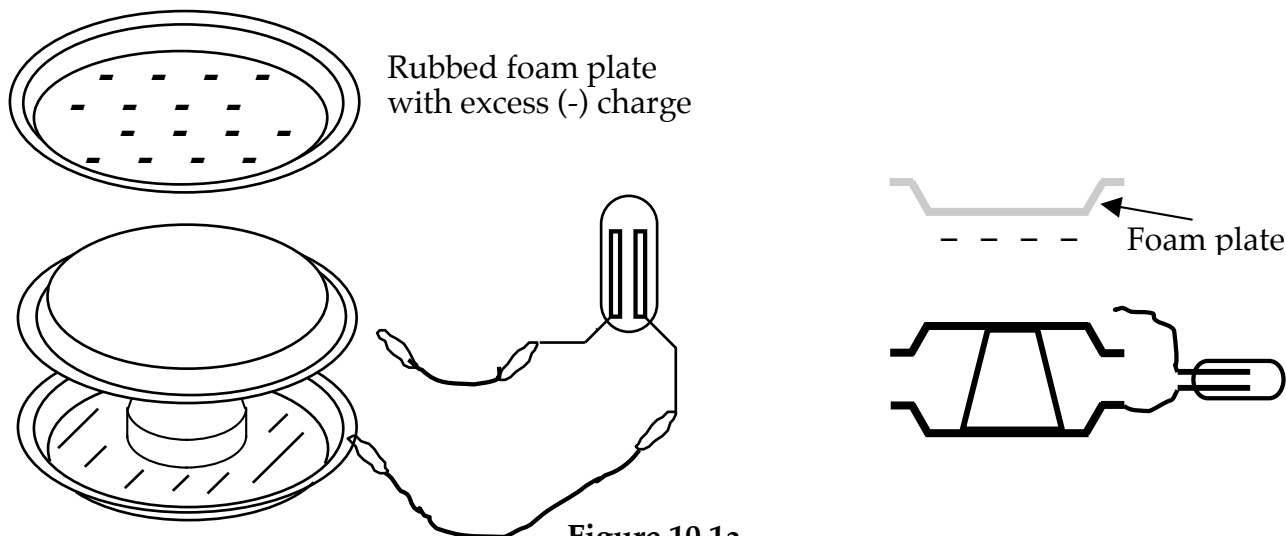

Figure 10.1a
TWO REPRESENTATIONS OF A PIE PLATE CAPACITOR

In this investigation you will use a pie plate capacitor plus an extra pie plate and foam cup. Tape the extra cup to the inside of the extra pie plate to serve as a handle, and connect the extra plate to the lower plate of the capacitor with a clip lead as shown in Figure 10.1b. Since the two lower plates are connected together with a conducting wire, they must have the same electrical pressure or electric potential.



Figure 10.1b
PIE PLATE CAPACITOR AND EXTRA PLATE

Now take a foam picnic plate, rub it briskly with an acrylic sheet, and place it near the top pie plate. Recall from earlier work that the foam plate acquires an excess of (-) charge.



Figure 10.1c
ELECTRIC PRESSURES WITH NEGATIVE FOAM PLATE NEAR THE CAPACITOR

1. How will the potential pressure halo around the (-) charge on the foam plate affect electric pressure in each of the 3 pie plates? Write labels by each plate in Figure 10.1c.

2. When the neon bulb is connected as in Figure 10.1d, which way will conventional charge flow due to the potential pressure difference? Draw an arrow on the diagram.

3. Which of the neon bulb electrodes do you predict will flash?

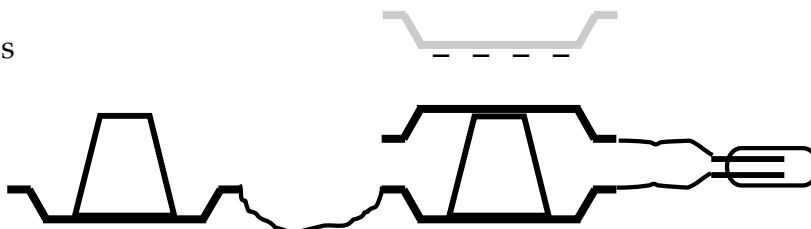

Figure 10.1d
CONNECTING THE NEON BULB

Connect the bulb and check your prediction.

4. Does the top plate of the capacitor end up with excess positive charge or excess negative charge?

5. Do the bottom capacitor plate and the extra plate end up with excess positive charge or excess negative charge?

6. When the neon bulb is disconnected and the pressure lowering effect of the negative foam plate is removed by moving the foam plate away, which pie plate or plates will have higher pressure and why? Which will have lower pressure and why?

7. Describe an experiment that can test your prediction.

Perform the experiment and check your prediction.

10.2 Activity: Making sparks jump

Charge the pie plate capacitor as shown in Figure 10.1d, and carefully disconnect the wire from the neon bulb that touches the top plate. Make sure not to touch the top plate with your hand in the process. (If you do, simply repeat the process of charging the plate.)

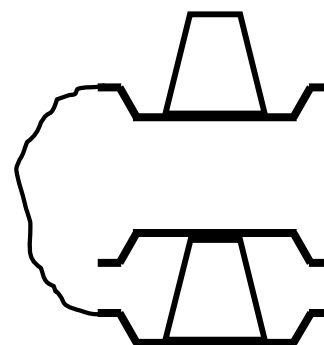

Figure 10.2
MOVING THE PLATES TOGETHER

Pick up the extra plate by the foam cup handle, and bring it about as far above the top capacitor plate as the bottom plate is below the top plate. Then carefully lower the extra plate towards the top plate -- getting closer and closer until a spark jumps. (See Figure 10.2) Repeat the experiment several times. Try tipping the top plate slightly as you do this -- to make the plates closer at one point than elsewhere. Watch and listen for the spark.

- a. Label the charges on the three plates in Figure 10.2, just prior to the spark.
- b. How close do the plates have to be, in order for a spark to jump between them?

With the neon bulb, we found that neon gas was an insulator until we reached a high enough pressure difference to make the neon gas become a conductor. For a spark to jump through air, which is normally an insulator, the air must become a conductor.

1. Assume the potential difference between the top and bottom capacitor plates is 1000 volts. What happens to the potential difference between the extra plate and the top plate while the extra plate is being moved closer?
2. How does the potential difference between the top and bottom plates compare with the potential difference between the top and extra plates?
3. What is different about the arrangement of the extra and bottom plates relative to the top plate of the pie plate capacitor at the instant the spark jumps?

10.3 Activity: Analyzing the condition for a spark

Clearly it is not only the electric potential difference but also the distance between the charged pieces of metal that determines when a spark occurs. We will use the idea of the potential halo to see what the nature of the situation might be. We will simplify our diagrams even further by showing the pie tins as simple flat plates.

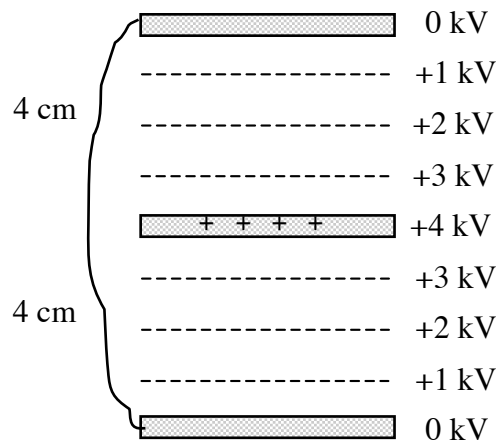

Figure 10.3a
PLATES FAR APART

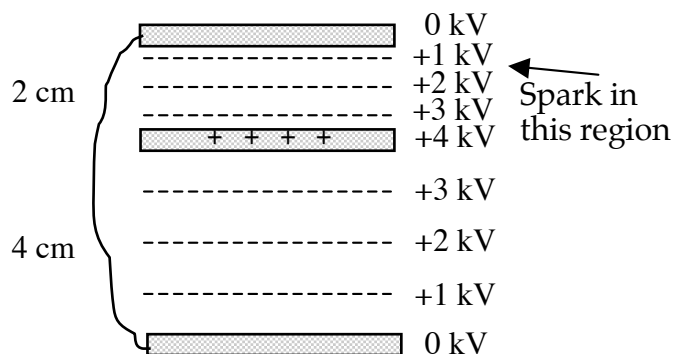

Figure 10.3b
EXTRA PLATE CLOSER TO TOP PLATE

Figure 10.3a shows the three plates. We have indicated a potential of 4 000 volts or 4 kilovolts for the potential of the top capacitor plate, and 0 volts for the potential of the bottom capacitor plate and the extra plate, and have drawn the lines of equal potential pressure at 1 kilovolt intervals.

1. What happens to the values of the lines of equal potential as the plates move closer together?
2. What happens to the value of the potential difference between the top plate and the bottom and extra plates as the extra plate moves closer together?
3. What has happened to the spacing of the lines of equal potential pressure as the extra plate moves closer to the top plate?
4. Calculate the ratio of the potential difference in kilovolts to the plate separation in centimeters for upper and lower portions of figure 10.3b. Which region has the greater ratio of potential difference to spacing of the equal potential lines?
5. Which quantity, (a) potential difference or (b) the ratio of potential difference to distance between equal potential lines, is a better predictor of where a spark will jump?

10.4 Commentary: The idea of “Electric Field”

In order for a spark to jump from one pie plate to the other, the air between the plates must change from insulator to conductor. Air consists of molecules and atoms with (+) and (-) parts that are held together by mutual attraction. For air to become a conductor, the (+) and (-) parts of some of the atoms must break apart and be free to move.

Our earlier work with neon bulbs provided evidence that the (+) and (-) parts of atoms can break apart in the presence of a sufficiently large potential difference. Our new experiment with pie plates shows that this breakup occurs only if the large potential difference is across a sufficiently small distance. It suggests that breaking the (+) and (-) parts of atoms apart requires a large ratio of potential difference to distance the potential difference is across.

This ratio is the magnitude of a newly discovered causal agent in halos that can break atoms apart. We were not aware of its existence before we investigated sparks – because our observations could not distinguish its effects from the effects of potential difference alone. Now that we have become aware of its existence, we need to find words to describe it.



Let's begin the job this way:

- A causal agent that's not been accounted for exists in the space around charged objects. It acts directly on (+) and (-) parts of any nearby atom, pushing them in opposite directions. We will call this new-found causal agent an “Electric Field”.
- Electric field exists in the same space as electric potential. Thus a halo includes both. So it is reasonable that the electric field strength at each point in a halo is related to the potential difference over a region of space that includes the point.

We will use the symbol E for the magnitude of an electric field's charge-pushing ability, and will call E the “Electric Field Strength”. Our pie plate experiment showed that E is large at points in a region with a large ratio of potential difference ΔV to the distance Δx that this potential difference is across. So it is reasonable to assign a value to E which is equal to the ratio $\Delta V / \Delta x$. This relates electric field and electric potential through the equation

$$E = \frac{\Delta V}{\Delta x}.$$

10.5 Activity: Electric field in a circuit

Electric field is present in circuits along with electric potential. Consider the two circuits in Figure 10.5a. The circuit on the left has one cell connected to a resistor. The circuit on the right has two cells in series connected to the same resistor.

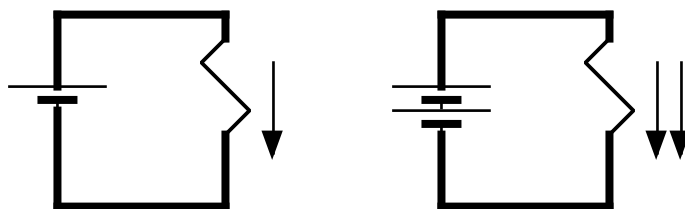

Figure 10.5a
TWO CIRCUITS

We know that the charge flow rate through the second circuit is twice that through the first circuit. Suppose the resistor is 0.25 cm long and each cell has 1.5 volts potential difference.

1. Calculate the ratio of potential difference to distance for the two circuits, and compare the values.
2. In which circuit is the electric field strength in the resistor greater? In which circuit is the electric field driving a greater charge flow rate through the resistor?
3. In Figure 10.5b you see an exaggerated diagram of the two resistors, with the lines of equal potential drawn at intervals of a half a volt. Draw and label the lines of equal potential at half-volt intervals for the second resistor. Which resistor has the greatest "crowding" of potential lines? Which resistor has the greatest electric field strength?

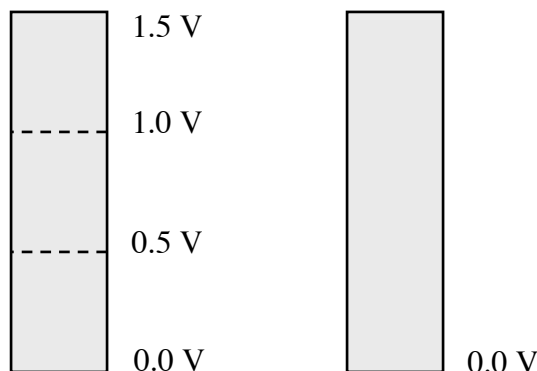

Figure 10.5b
EXPANDED VIEW OF THE RESISTORS IN THE TWO CIRCUITS

4. In the case of the resistor connected to a battery cell, we "crowded" the lines of equal electric potential closer together inside the resistor by adding a second cell which doubled the potential difference across the resistor. In the case of the pie plate capacitor with an extra plate placed above it as in Figure 10.2a, we "crowded" the lines of equal potential in the upper space by moving the extra plate downward, closer to the capacitor.

Suppose we now remove the wire connected to the extra plate (as it was in Figure 10.5a), and then reduce the potential of the bottom plate to -4 kilovolts by adding extra $(-)$ charge to that plate. On Figure 10.5c, draw and label the lines of equal potential between the middle and bottom plates at intervals of 1 kilovolt. Compare the "crowding" of potential lines in the regions above and below the middle plate. Calculate and compare the electric field strength in these two regions.

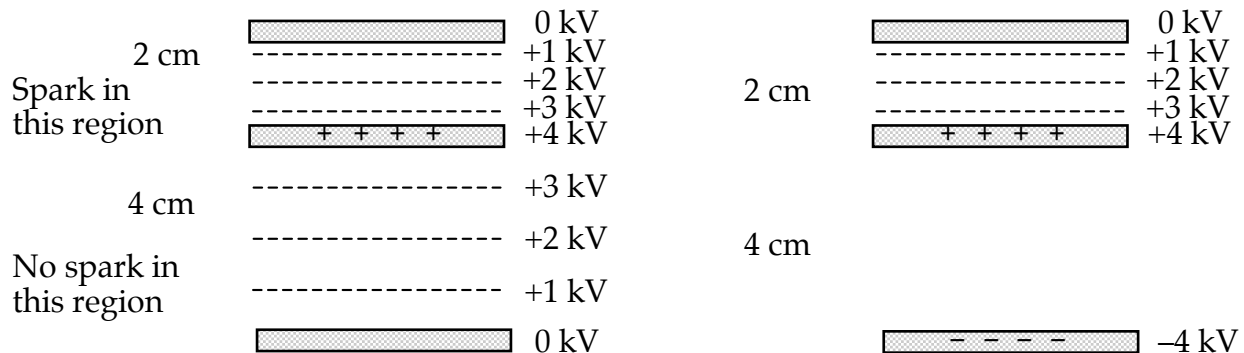

Figure 10.5c **Figure 10.5d**
CHANGING HALO LINE SPACING BY CHANGING
POTENTIAL DIFFERENCE

10.6 Commentary: Electric field is a new causal agent

In our work in circuits, we found that the idea of electric pressure was sufficient to account for the flow rates of charge moving in circuits. So it made sense to think of electric pressure difference (or potential difference) as the universal causal agent of charge flow. This idea works well for explaining current propulsion in a connected system of circuit components.



But when we investigated the conditions for forming sparks in air with a pie plate capacitor, we found that pressure difference alone is not sufficient to explain why charge moved and sparks were formed. With the same potential pressure difference, whether a spark was formed or not depended also on the distance over which the pressure difference occurred.

Forming sparks in the air gap between two charged plates required action by a sufficiently strong electric field in the space between the plates. Here, electric field can be seen as the causal agent that pushes directly on the tiny particles of charge inside atoms – and which, if strong enough, can drive electrons out of their normally stable homes in atoms. This makes electric field a truly universal causal agent. Though the potential halo around the plates occupies the same space as the electric field, there is little or no potential difference across such tiny particles.

But electric potential, which pushes charge through a resistor indirectly, through competing pressures in other charge in wires on opposite sides of the resistor, is much easier to use with circuits. To analyze circuits using electric fields, we would first have to find out where the charges are located whose electric fields are pushing electrons through the resistor. If we use electric pressure instead, we can reason with fluid pressure and conclude that one wire has uniform high pressure and the other has uniform low pressure. So we don't have to know where much of the extra (+) and (-) charge in a circuit is located.

In conclusion: Electric potential and electric field belong to the same halos and imply the same conclusions. Use whichever is more convenient for dealing with the problem at hand.

Historical Note – Franklin's sparks and American independence

In the mid-1700s, Benjamin Franklin discovered that sparks between electrified conductors jump preferentially between places that protrude or stick out. His letters about the "power of points" and other discoveries about electricity were published in Britain and France, and made him well known among scientists in Europe. Along with others Franklin had proposed that lightning might be an electric spark through air, but Franklin alone designed an experiment using a lightning rod to test this idea. He also proposed the use of lightning rods to protect buildings and ships from harm. A successful lightning rod test in France in 1752, followed by Franklin's famous kite experiment, produced widespread admiration for Franklin.

The French respect for Franklin led to his appointment as one of the American Commissioners to France during the American Revolution – and in that role he helped persuade the French to enter the war on the American side. The alliance with France that Franklin brokered turned out to be crucial in the battle of Yorktown, which ended Britain's effort to throttle American independence. A naval victory by the French fleet against the British fleet at the entrance to Chesapeake Bay blocked General Cornwallis, the British commander, from retreat by sea – forcing his surrender.

Had his lightning experiment and electrical research not made Franklin famous in France, the French navy might not have been there to help Washington's troops win the battle of Yorktown. Cornwallis might then have retreated by sea, landed again north of Yorktown, and put American independence in doubt.



INVESTIGATION TWO: WHAT DO ELECTRIC FIELD PATTERNS LOOK LIKE?

We will now investigate the directions of pushing ability by electric fields in the space near large charged objects. To detect these directions we will use an electric compass – made by adding (+) and (-) charged tapes to a versorium like the one you used in Section 8.

10.7 Activity: The electric compass

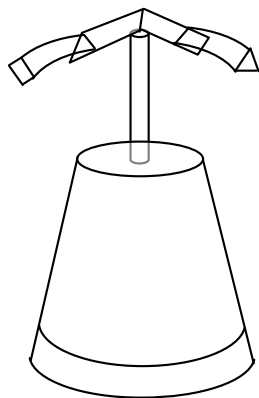

Figure 10.7a
ELECTROSTATIC
COMPASS

To construct an electric compass, make a paper versorium with a short paper section.

Make a pair of pointy and blunt tapes about 6 cm (three finger widths) long. Stick the pointy tape to the slick side of the blunt tape, press them together, and peel them apart, as before.

Tape the pointy tape to one end of the paper section and the blunt to the other as shown in figure 10.7a. The paper section with tapes added will be the pointing “needle” of your electric compass.

The paper section with both tapes added will be the pointing “needle” of your electric compass.

1. Rub an acrylic sheet against a foam picnic plate. Hold the acrylic with one edge upward, and move the electric compass to different locations near the faces of the acrylic. Draw an arrow on the diagram below to show the direction in which the “needle” of the compass points at each compass location.

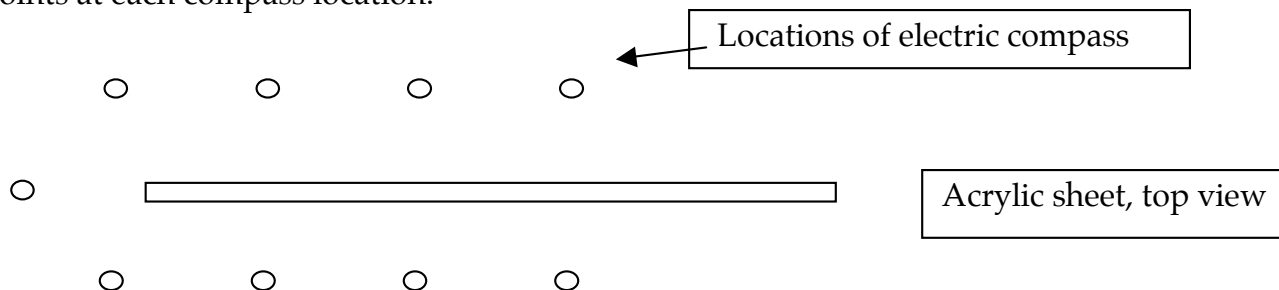

Figure 10.7b
MAPPING ELECTRIC EFFECTS NEAR ACRYLIC PLATE

2. What can you say about the direction the electrostatic compass points?

3. How would you explain the reason the electrostatic compass points as it does, in terms of pushes and pulls on the pointy and blunt tapes?

4. Which way does the electric compass “needle” point in relation to electric potential?

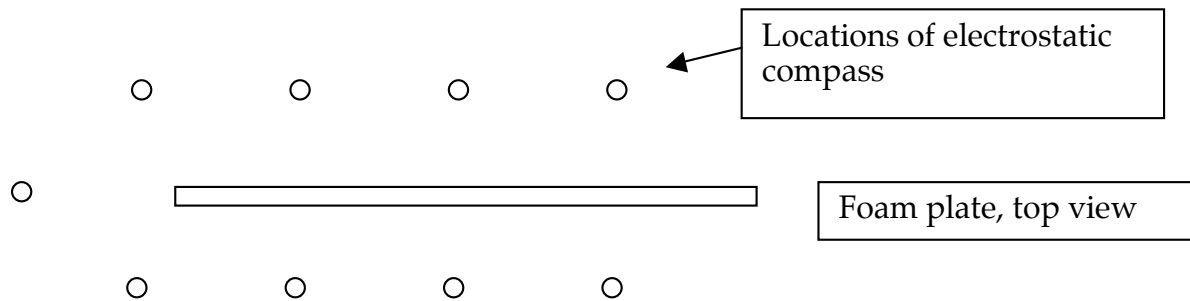
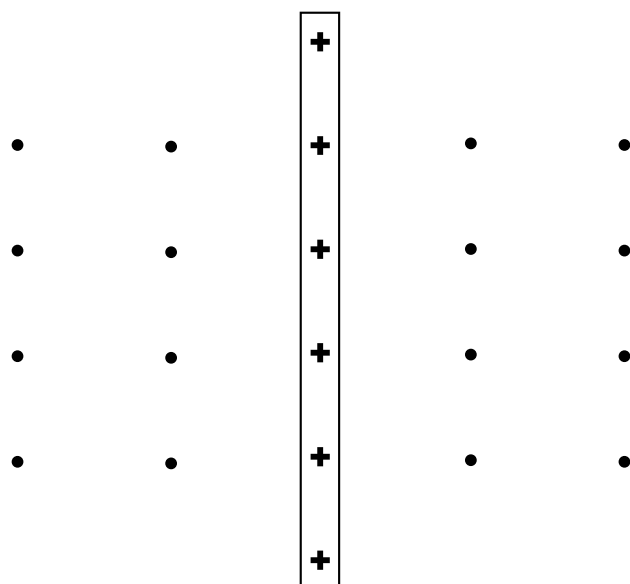

Figure 10.7c
MAPPING ELECTRIC EFFECTS NEAR FOAM PLATE

5. Take the foam picnic plate or a large sheet of polystyrene foam. Rub it with acrylic and set it up on edge. Repeat the investigation.

6. What do you find the same and what do you find different about the pattern?



7. Which end of the electrostatic compass points to lower potential?

8. How would you expect the pattern of arrows to differ if the thin charged plate were made very large? Imagine the plate in Figure 10.7d continuing sideways for a great distance -- so that we have drawn only a very small section of the plate.

9. Sketch the direction you would expect the electric compass to point at each of the dots in the space near the positively charged plate.

Figure 10.7d
MAPPING ELECTRIC COMPASS
DIRECTIONS NEAR A VERY LARGE (+)
PLATE

10. Now imagine that you have charged a thin flexible sheet of foam instead of a rigid foam plate -- and then wrapped it into a cylinder and surrounded it with electrostatic compasses. Draw arrows to represent the directions you predict the compasses would point at each of the points on Figure 10.7e.

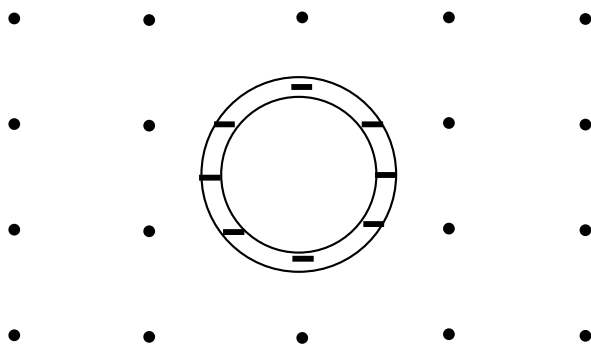

What is your reason for choosing the directions for the arrows?

Test your idea by rubbing a foam cup with a piece of wool. Set it on top of another foam cup and move your electric compass around near it. Was your prediction correct?

Figure 10.7e
MAPPING ELECTRIC EFFECTS NEAR A
NEGATIVE CYLINDER

11. So far, you have drawn arrows to represent the directions the electrostatic compass will point in the space around an accumulation of (+) or (-) charge. Note that there is a pattern to these directions – and that this pattern is closely related to the pattern of electric potential near that charge. The direction the electric compass “needle” points is always from higher potential to lower potential. If there were no differences in potential, the compass would have to point somewhere, but not in any organized way. In such cases, it would make more sense not to draw any arrows at all.

Figure 10.7f shows two large charged plates -- one (+) and one (-) like you would have in a charged capacitor. At the location of each dot, draw the direction you would expect an electric compass “needle” to point. If you find a point where there is NO DIFFERENCE of potential in a small region around the point, then do not draw an arrow at that point.

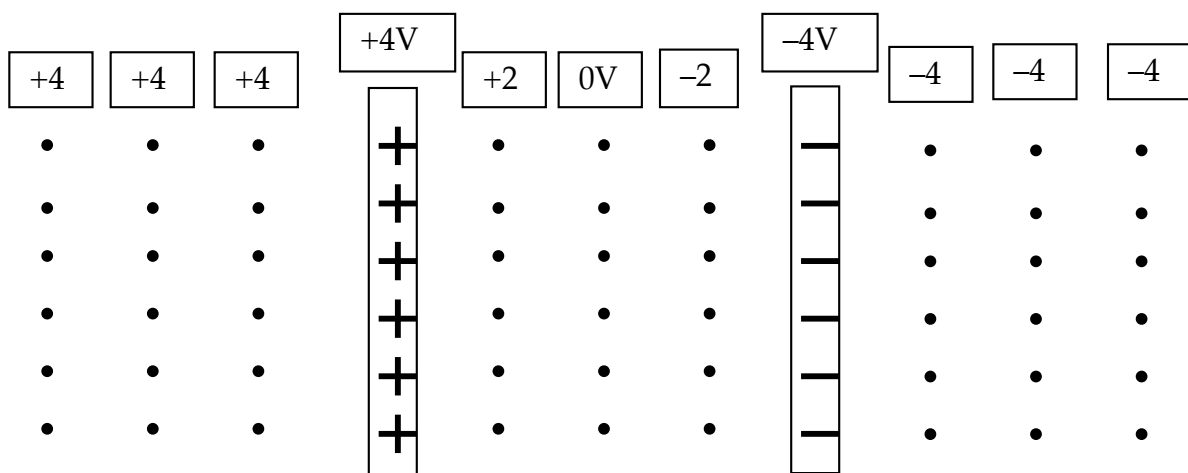

Figure 10.7f
ELECTRIC COMPASS PATTERNS NEAR OPPOSITELY CHARGED PLATES

12. For simplicity, we have been drawing portions of large charged plates in cross section. It can be useful to see a three-dimensional projection of the electric field between portions of two large plates. Figure 10.7g shows such a view.

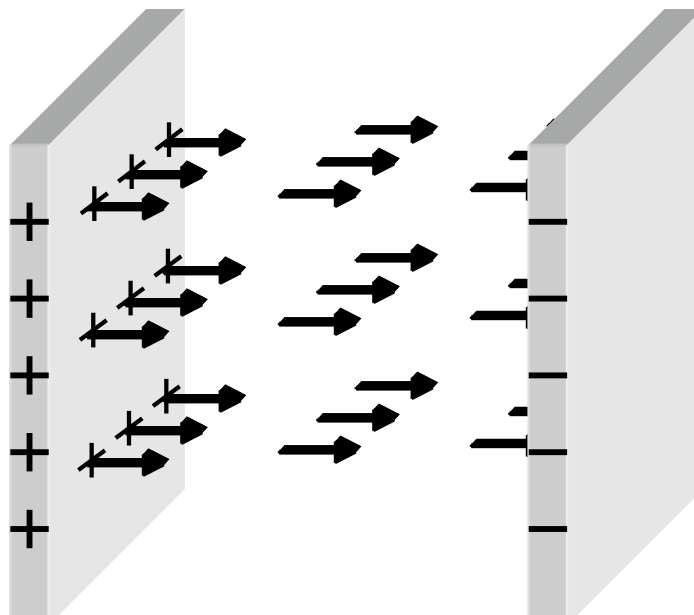

Figure 10.7g
ELECTRIC FIELD BETWEEN PORTIONS OF TWO
LARGE OPPOSITELY CHARGED PLATES

10.8 Activity: Potential halo lines and electric field vectors between parallel plates

How are the electric field patterns related to the potential halo patterns? Figure 10.8a shows a cross-section of two large parallel plates with a potential difference of 4 volts across them.

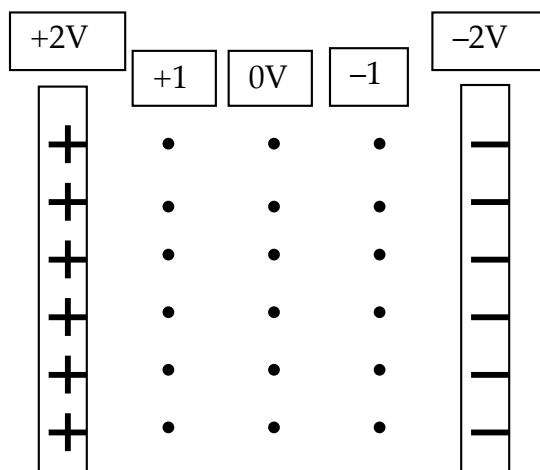

Figure 10.8a
ELECTRIC POTENTIAL AND ELECTRIC FIELD PATTERNS NEAR
OPPOSITELY CHARGED PLATES

1. Draw the lines of equal electric potential at one-volt intervals between the plates.
2. Imagine that you have placed electric compasses at each of the points shown between the plates. Draw an arrow showing the direction of the electric field at each point.

3. What is the direction of the field direction arrows relative to the potential halo lines?
4. Compare this diagram with that of Figure 10.7f. What would be the value of the electric potential at any point in the region to the left of the (+) plate? At any point to the right of the (-) plate?
5. How much does the electric potential change as you move through any distance in the region to the left of the positive plate? What would the electric field strength be at points to the left of the positive plate?

10.9 Activity: Electric potential lines and field directions near a charged metal sphere.

Suppose that you take a metal sphere and charge it negatively, as shown in cross-section in Figure 10.9a. The labeled points on the right of the sphere show the value of the electric potential at those points.

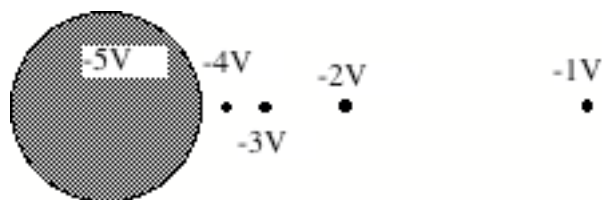

Figure 10.9a
ELECTRIC POTENTIAL LINES AND ELECTRIC FIELD
VECTORS NEAR A CHARGED SPHERE

1. Carefully draw the correct lines of equal potential that would pass through those points.
2. On each equal potential line, draw eight evenly spaced field direction arrows pointing in the direction an electric compass “needle” would point.
3. What angle do these field direction arrows make relative to the equal potential lines?

4. Now look at the distances between the lines of equal potential. Where is the largest potential difference per millimeter of distance from the center? Where is the smallest potential difference per millimeter of distance from the center?

5. What is the implication for the value E of the electric field strength in the same space?

It is helpful to represent field direction and field strength together in a single mathematical entity. So we will now combine field direction arrows and field strength magnitudes into ELECTRIC VECTORS. These vectors can be represented on diagrams by making the field direction arrows wider where the field strength magnitude is greater, and thinner where the field strength magnitude is smaller.

6. Repeat your work on the copy of the diagram below, first drawing the equipotential lines but this time make your field direction arrows dark and heavy where the electric field is strongest, and leave them thin where the field is weakest.

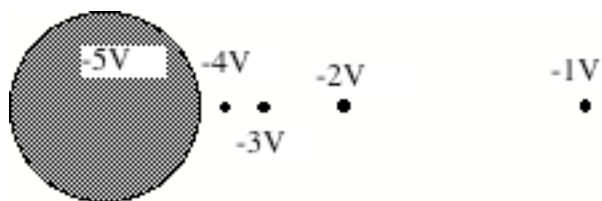

Figure 10.9b
ELECTRIC POTENTIAL LINES AND ELECTRIC FIELD VECTORS
NEAR A CHARGED SPHERE

10.10 Activity: Electric potential lines and electric field vectors.

Rather than draw individual arrows to represent the electric field direction at each point in the halo of charged objects, it is a convention in physics to simply draw lines which represent the electric field direction. The strength of the electric field is greatest where the density of lines is largest. Using this convention the diagrams for the charged parallel plates and the charged sphere would look like those in Figure 10.10. (Note that the electric field lines have an arrow on one end, and in these diagrams have been drawn thicker than the potential halo lines.

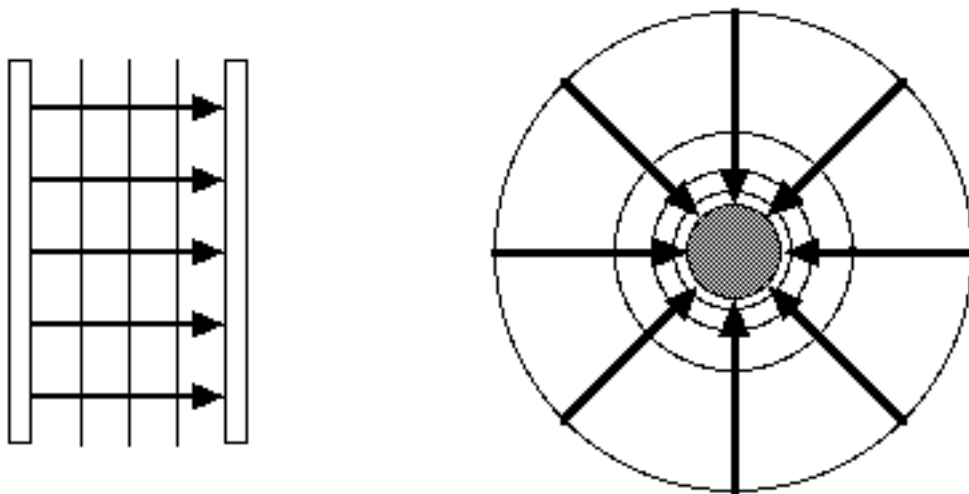

Figure 10.10
ELECTRIC EQUIPOTENTIAL LINES AND ELECTRIC FIELD LINES FOR PARALLEL PLATES AND A CHARGED SPHERE

1. Label the two plates with the sign of their charges. Label the charged sphere with the sign of its charge.
2. How can you tell by looking at the electric field line whether a charged object has a positive or negative charge?

INVESTIGATION THREE: RELATING ELECTRIC FIELD & ELECTRIC FORCE

10.11 Activity: Thought Experiment – Electric force and electric field.

1. Consider a large positively charged plate (of which we only see a small part) with a potential of 4 Volts, which generates a potential halo that diminishes with distance so that at one centimeter of distance the potential halo has a value of 2 volts and at two centimeters of distance a value of 0 volts. Using our definition of electric field from Investigation One, we find an electric field value of 2 V/cm, with a direction from left to right.

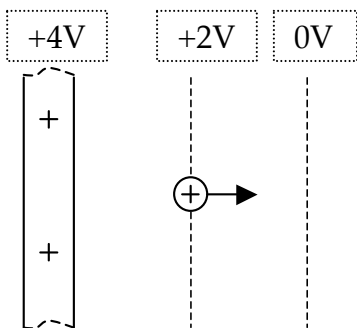

Figure 10.11a

Place a very small positive test charge one centimeter away from the plate. It will be pushed away from the plate, from high potential towards lower potential, by an electric force. We will assume that the force on this particular charged object is 0.2 millinewtons (Figure 10.11a).

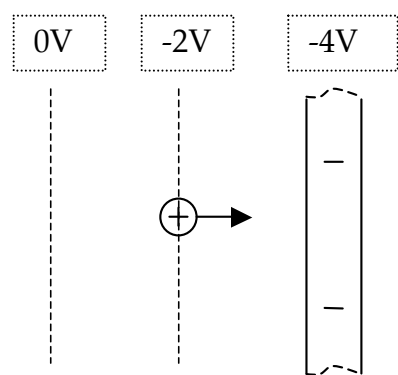

Figure 10.11b

2. Suppose we instead put a negative plate to the right of the location of the test charge. What is the direction of the electric field due to the negative plate? (Figure 10.11b)

How much does the potential change for each unit of distance moved as you approach the negative plate?

3. Comparing this situation with the first one, how much force would be pushing on the charge in this case?

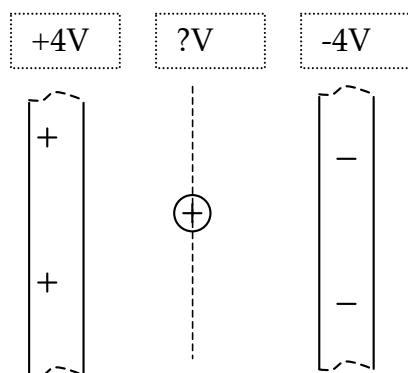

Figure 10.11c

4. What do you think would be the effect on the force on the test charge if we now put the positive plate one unit of distance to the left of the charge and the negative plate one unit of distance to the right of the charge at the same time?

5. Draw one arrow to represent the force due to the positive plate. Draw a second arrow to represent the force due to the negative plate. What would be the value of the combined force on the charge?

6. What would be the value of the electric potential at the equipotential line halfway between the two plates? What is the total change in potential in traveling the two centimeters from one plate to the other? What is the ratio of the change of potential to change of position (the value of the electric field strength)?

7. How does the electric field strength for this situation compare with that of Figure 10.11a?

10.12 Commentary

The combination of the two plates causes twice the force on the small test charge and there is also twice the electric field strength between the plates. Along with the results of our experiment with the sparks in Investigation One, this suggests that increasing the electric field strength at some location increases the electric force on a small test charge at that location. But is electric field strength the same as electric force? The next thought experiment will investigate what else the electric force on an object must depend on.

10.13 Activity–Thought experiment: Electric field, charge and electric force.

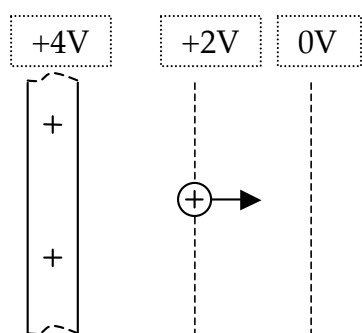

Figure 10.13a

Look again at the diagram (Figure 10.13a) showing a single charged plate with a small positive test charge near it. As before we will assume that the force on the charge is 0.2 millinewtons. We also know that the electric field in this region has the value of 2 N/cm.

Suppose we now increase the amount of charge on the object. This could be done by placing a second identically charged object at the same place and fastening them together. (Figure 10.13b.) Notice that we have not changed the charge on the large plate, so the electric field strength is still 2 V/cm.

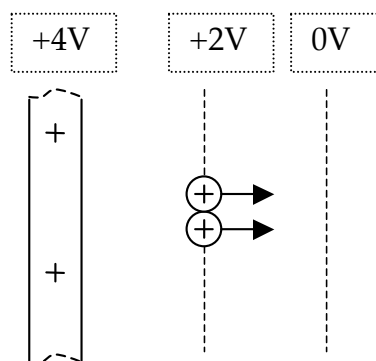

Figure 10.13b

1. What would be the total force on the combined object with twice as much charge placed at this same location relative to the same charged plate?

2. What is the ratio of force to charge or the amount of force for each unit of charge?

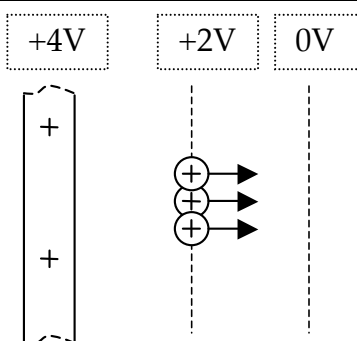

Figure 10.13c

3. Suppose we increase the charge to three times as much. How much total force would push on the charge at this same location? (Figure 10.13c.)

4. What is the ratio of force to charge for this situation?

5. What is the value of the electric field strength at this location?

10.14 Commentary: Electric field, electric force and electric potential



Although the force acting on a small charged object is greater with more charge on the object, you have found that the amount of force for each unit of charge, or the number of Newtons of force for each unit of charge is staying the same.

You have also seen that the value of the electric field strength or the rate of change of potential with change in position is staying the same.

- We find that when the electric field strength (crowding of potential halo lines) stays the same, the force pushing on each charge stays the same.
- We also found that when the electric field strength (crowding of the halo lines) increases, the force pushing on each charge increases.

This suggests that the numerical value of the electric field strength calculated from the crowding of potential halo lines, $E = \frac{\Delta V}{\Delta x}$ is also equal to the ratio of the force acting to the

charge acted on, $E = \frac{F}{q}$, where F stands for the force and q stands for the "quantity of

charge." Once we know the electric field at some distance from a charged object, we can find the force on any charge by rearranging the equation to solve for F. The unit of electric charge, the Coulomb, has been chosen so that the ratio of change in electric potential to change in position with units of Volts/meters is equal to the ratio of force for each unit of charge in units of Newtons/Coulomb.

10.15 Activity–Thought Experiment– Effect of electric field on negative charges

What would happen if we placed a small negative test charge in the space near a charged plate? (Figure 10.15a)

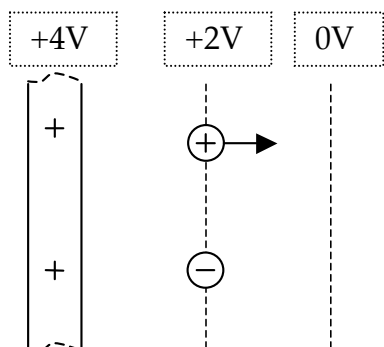

1. Draw four long arrows (electric field lines) to show the direction of the electric field in the space to the right of the charged plate. Label these lines "E".

2. The short arrow on the small positive test charge shows the direction of the electric force on the positive charge. Label this line "F+".

3. Draw a short arrow, labeled "F-", to show the direction of the electric push or electric force on the negative charge.

Figure 10.15a

4. How does the direction of the electric force on a negative charge relate to the direction of the electric field at the point where the charge is located?

5. If the amount of negative charge is the same as the positive charge, how would the magnitude of the forces compare?

Since the only difference would be the direction of the force, we choose NOT to define a second kind of electric field, but instead define the direction of the electric field as the direction of the force on a positive test charge.

When we calculate the force on a charge using the equation $F = qE$, the force will be in the same direction as the electric field if the charge q is positive, and in the opposite direction if the charge q is negative.

6. Now place a small piece of conducting material in the region where there is an electric field (Figure 10.15b). Remember that in solid conductors, we found that negative charges are the mobile charge carriers.

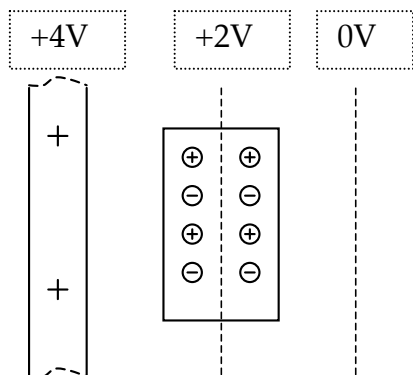

Figure 10.15b

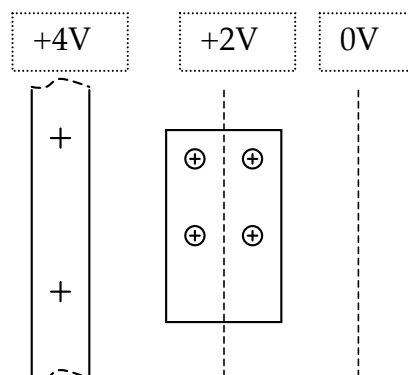

Figure 10.15c

Draw arrows to show the forces on the positive and negative charges in the metal in the figure at the left. Since the negative charges can move, they will move to the edge of the metal in the direction of the force. Draw the negative charges near the appropriate edge of the metal in Figure 10.15c.

Here we have used the electric field idea to explain the separation of (+) and (-) charges – called “polarization” – which occurs when materials are placed in a region where there is an electric field.

10.16 Activity: Thought Experiment – Superposition of electric field halos and electric potential halos.

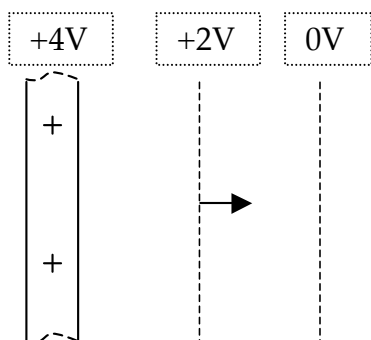

Figure 10.16a

Figure 10.16a shows the electric field at a point near a positively charged plate and the values of the electric potential in the space near the plate.

Figure 10.16b shows the electric field and electric potential due to an equally charged negative plate.

Suppose we now combine the two situations by putting both the positive (pressure raising) charge and the negative (pressure lowering) charge on the same plate. Then we have the situation shown in Figure 10.16c, where we have shown two field arrows – one due to the positive charge and one to the negative charge.

1. What must the value of the combined field be?

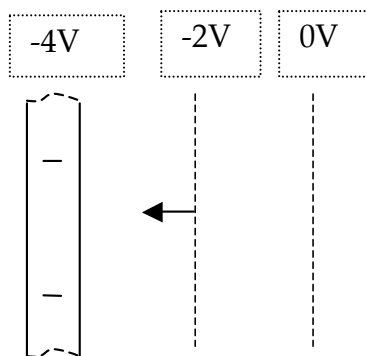

Figure 10.16b

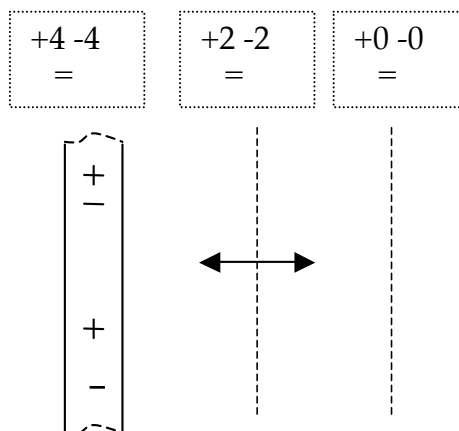

Figure 10.16c

2. Fill in the potential values for the locations shown in Figure 10.16c. Does the potential change with change in position?

3. Would a charge placed in this area experience a force due to the combined electric field of the positive and negative charge?

This is an example of the superposition of electric fields and electric potential halos created by charges. We can figure out the electric field magnitude and direction and the electric potential halo values for combinations of charges simply by combining the effects of the individual charges.

We will now use this technique to find how the field in between the plates of a capacitor depends on the potential difference. What happens when you increase the charge on a single plate? Figure 10.16d shows a charged positive plate with potential values and a single electric field arrow.

4. If we double the charge on the plate by superposing a second set of positive charges. What is the new electric potential at the test charge location?

5. How much does the potential change for each unit of distance?

6. How would the electric field compare? Draw arrows to show the comparative field strength at the location of the test charge.

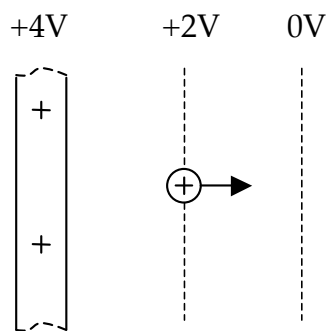

Figure 10.16d

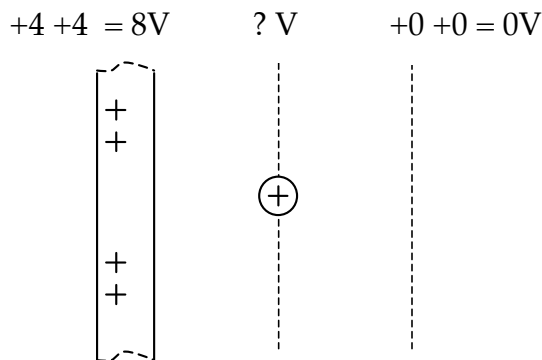

Figure 10.16e

Suppose we now combine a positive and a negative plate to build a charged capacitor (Figure 10.16f). Each plate has an electric potential halo (shown only on the right of the + plate and on the left of the - plate).

7. How does the field strength between the plates compare to the field of one of the plates?

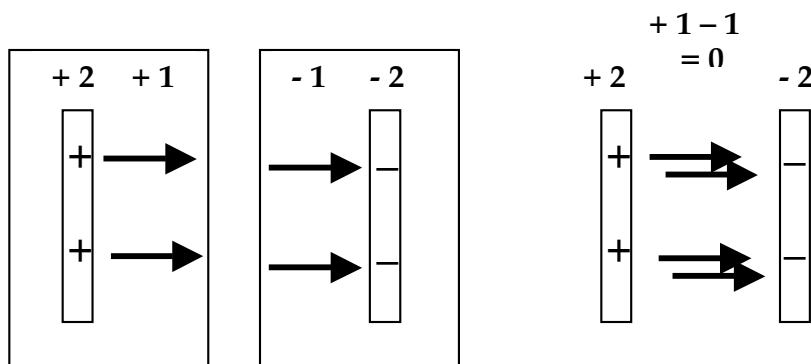

Figure 10.16f
ASSEMBLING A CHARGED CAPACITOR

Suppose we now double the charge on each capacitor plate, which we could do by doubling the number of cells connected to the plates. We can think of this as superposing two charged capacitors on top of each other. Figure 10.16g shows a single pair of charged plates on the left and plates with twice the charge on the right.

8. What would be the potential values and the field strength between the plates now compared to the single capacitor?

Write in the potential values for the plates and the line between them in the diagram for Figure 10.16g.

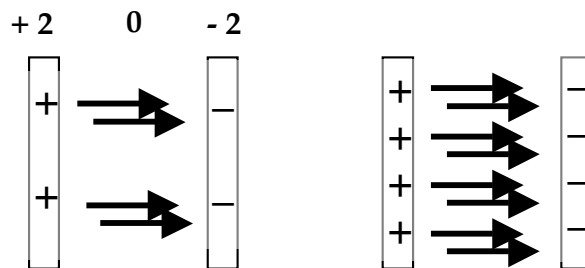

Figure 10.16g

9. If we double the charge on a capacitor, what does that do to the strength of the electric field between the plates?

What would it do to the potential difference between the plates?

10.17 Summary – The electric field idea

Looking back at the thought experiments we have just done by combining the effects of charged plates, you can draw several conclusions.

One: The direction of the electric field (force / charge) is always from _____ potential to _____ potential, and is the direction of the force on a _____ test charge.

Two: The value of the electric field in Newtons / charge is the same as the value of the _____ in electric potential divided by the distance moved, in Volts / distance.

Three: The electric field created by a combination of electric charges is simply the combination of the _____ created by each electric charge.

Four: The value of the force acting on a given amount of charge at a particular location can be found by multiplying the amount of _____ by the value of the electric field (in Newtons / charge) at that location.

Equation for electric field strength: $E = \frac{F}{q}$

in units of Newtons / Coulomb

Equation to find force exerted by the field: $F = qE$

Relation between electric field and electric potential difference with distance:

$$E = \frac{\Delta V}{\Delta d} \quad \text{in units of Volts / meter.}$$

Thus a change in potential of 5 Volts for each meter would produce an electric field strength of 5 Newtons / Coulomb. This means that the units of electric field (Newtons / Coulomb) are interchangeable with the units of potential difference over distance (Volts / meter).



INVESTIGATION FOUR: HOW MUCH ENERGY DOES AN ELECTRIC FIELD STORE?

How is energy stored in a capacitor? What is the relationship between potential difference, electric field and energy storage? In this investigation you will explore the way that energy is stored in a capacitor.

10.18 Activity: Feel the force

1. Take a foam plate and an acrylic sheet and rub them together to separate charge. Hold the pair of them with the acrylic plate on top and the foam plate below. Pull down on the foam plate. Do you feel a force pulling up?
2. After separating the foam from the acrylic, bring the acrylic closer and closer to the foam. What happens to the foam plate?
3. Did it take “work” – expenditure of energy on your part – to separate the foam and acrylic?
4. Did the foam and acrylic move back together when brought close?



If you have to give up some energy to pull two objects apart, then there must be energy stored in some fashion while the objects are apart.

When we pull apart objects connected by a spring that tries to pull them back together, we think of this energy as being stored in the spring. Experiments show that in many springs energy is stored in proportion to the square of the length the spring is stretched.

When the objects are connected by an electric field that tries to pull them back together, it seems natural to think of this energy as being stored in the electric field. Bulb lighting by a charged capacitor definitely shows that the capacitor stores energy when there is an electric field between its plates.

10.19 Activity: Energy and electric field strength in capacitors

We already found that the electric field in a capacitor is determined by the potential difference between the plates and the separation between the plates. If we keep the plate separation the same, doubling the potential difference will also double the electric field.

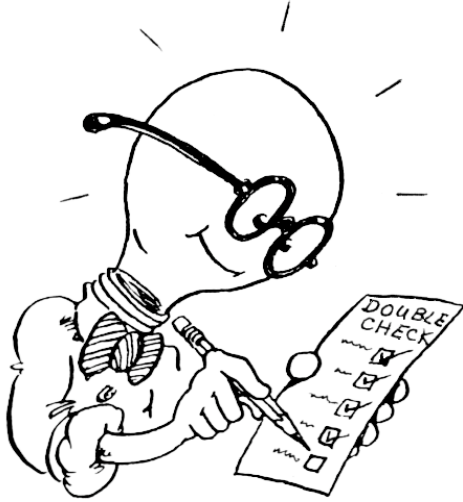

Get together with another group for this activity, as you will need to share equipment. Construct the initial circuit shown in Figure 10.19a, using two cells, the $25,000\ \mu\text{f}$ capacitor and a single long bulb. First connect the battery pack to the capacitor and wait a few seconds. As you know, this will charge the capacitor, and establish an electric field between the plates.

Disconnect the battery pack from the capacitor, and discharge the capacitor through the single long bulb, noting how long the bulb lights and how brightly it lights. Repeat the charging and discharging several times so you get a good idea of the time and brightness. Obviously it took a certain amount of energy to light the bulb, energy that must have been stored in the capacitor.

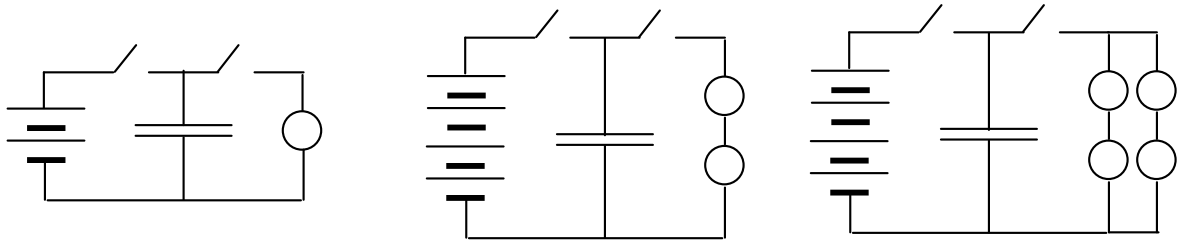

INITIAL CIRCUIT

Figure 10.19a
DISCHARGE WITH
TWO BULBS

DISCHARGE WITH
FOUR BULBS

What do you think would happen if you charged the capacitor with twice the potential difference? We know that would double the electric field strength – so would it also double the energy stored? To test this possibility, construct the second circuit shown in Figure 10.19a, using two battery packs with a total of four cells. That will double the potential difference. If it also doubles the amount of stored energy, then the TWO long bulbs should light with the same brightness and for the same time as the single bulb did in the two cell circuit.

Connect the cells and charge the capacitor, then disconnect the battery and discharge the capacitor through the two bulbs.

1. How did the lighting time compare with the single bulb?

Less than? Same as? More than?

2. Was the amount of energy stored at twice the potential, and with twice the electric field strength?

Twice as much? Less than or more than twice as much as in the first case?

3. Now modify the circuit by adding another set of two long bulbs, so that there are four long bulbs as in the third circuit in Figure 10.19a. Charge and discharge this capacitor and compare the bulb lighting time and brightness with that of the single bulb. How do they compare with the lighting time and brightness of a single bulb?

Less than? Same as? More than?

4. With twice the electric field, how many times as much energy was stored in the capacitor?

It seems that with twice the electric field in the region between the capacitor plates, there was more than twice the energy stored.

Try another experiment to see what happens when three times the potential difference is used to establish three times the electric field. Use six cells to charge the capacitor. Try discharging through 3 long bulbs in series, through two parallel sets of 3 long bulbs in series (a total of six bulbs), and finally through three parallel sets of 3 long bulbs in series (nine bulbs total.) You may need to share equipment with a third group.

5. **Predict** which combination you expect to give the best match with the single bulb discharging the capacitor charged with two cells.



6. What was your result?

7. Summarize the results of the three experiments in the table at right. How are the amounts of energy stored related to the strength of the electric field between the plates?

E Field	Energy Stored
1.	
2.	
3.	

10.20 Activity: Energy and the electric field

In the previous activity you found that the amount of energy stored in a capacitor was proportional to E^2 , the square of the electric field strength. Obviously this can't be the whole story, since you have earlier seen that two capacitors in parallel store more energy than a single capacitor. What property of the field besides its strength determines the total amount of energy stored? This activity will help you find out.

For each of the steps in this activity you will use the two cell charging circuit shown in Figure 10.20a. (You will need to share equipment with another group for this activity.)

Start by charging the 25,000 μf capacitor, then disconnect the capacitor from the charging circuit and discharge it through a single long bulb as in the figure. Notice the bulb brightness and lighting time – this will be your measure of the energy stored.

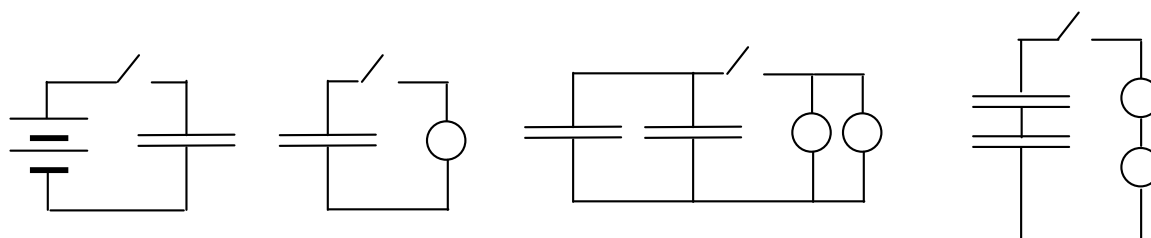

Figure 10.20a

**CHARGING
CIRCUIT**

**DISCHARGE
WITH ONE BULB**

**PARALLEL DISCHARGE
WITH TWO BULBS**

**SERIES DISCHARGE
WITH TWO BULBS**

Next charge two capacitors, one at a time using the charging circuit. Connect them in parallel and then discharge through two long bulbs in parallel. (CAREFUL – make sure you connect the two negative plates of the capacitors together, and the two positive plates together after charging.)

1. How much total energy was stored in the two capacitors compared to one?

Next charge two capacitors, one at a time, and this time connect them in series, and discharge through two bulbs in series. (CAREFUL – make sure you connect the positive plate of one capacitor to the negative plate of the other after charging)

2. How much total energy was stored in the two capacitors compared to one?

To make sense of your result, it is useful to visualize the field between the plates as they are combined. Figure 10.20b shows at the left a single capacitor with the electric field represented by arrows. This represents a single charged capacitor. In the second diagram you see a pair of equally charged capacitors in parallel. In the third diagram you see two equally charged capacitors in series. The field strengths are the same in between each pair of plates, but the volume of space containing the field has changed.

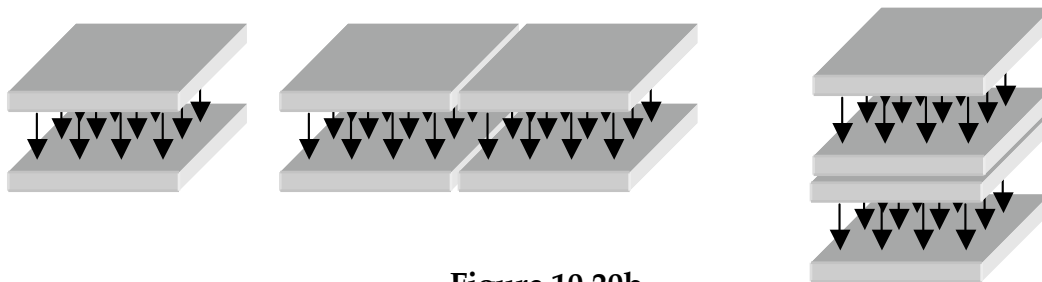

Figure 10.20b
COMBINING VOLUMES CONTAINING ELECTRIC FIELDS

3. Compared with the first diagram, how much has the volume increased in the second diagram?
4. How much did the total energy change with two equally charged capacitors in parallel compared to one?
5. Compared with the first diagram, how much has the volume increased in the third diagram?
6. How much did the total energy stored change with two equally charged capacitors in series?

In this activity, you have seen that with the strength of the electric field held constant, the amount of energy stored is proportional to the volume of space occupied by the field.

In the previous activity, you saw that with the volume of space occupied by the field held constant, the amount of energy stored is proportional to the square of the electric field strength.

IF both volume and field strength can change, THEN the total energy stored in a region of space must be proportional to the product of the volume and the square of the field strength or

$$\text{StoredEnergy} \propto (E^2) \times (\text{Volume})$$

10.21 Commentary – Energy storage in the electric field

We have found that the amount of energy stored in a volume of space is proportional to the square of the electric field strength in that volume and to the amount of volume occupied by the field.

Does the amount of energy stored depend on anything else? Yes, it also depends on the nature of the insulating material that occupies the volume. Careful experiments with identical capacitors using different insulating materials show that putting an insulator in the space between the plates increases the energy stored compared with what would be stored if the insulator were a vacuum.

For a vacuum, the energy stored is given by

$$Energy = \frac{1}{2} \epsilon_0 E^2 \times Volume$$

Here ϵ_0 is a constant that makes the units of energy, electric field strength and volume fit together – much like π is a constant that makes the units of radius and circumference fit together (and is sometimes called the “permittivity of empty space”).

For an insulating material other than vacuum, the energy is larger by a factor κ called the “dielectric strength” of the material. The amount of stored energy is then given by

$$Energy = \kappa \left(\frac{1}{2} \epsilon_0 E^2 \times Volume \right)$$

Typically, materials like plastics have a dielectric strength between 2 and 10 times that of vacuum.

10.22 Activity: Thought experiment – Changing plate separation

In Activity 10.18 at the beginning of this investigation, you rubbed foam and acrylic plates together, and then pulled the charged plates apart. You could feel a force of attraction between them, and since you applied a force through a distance, you must have stored energy as you separated them. The same thing could be done by charging the plates of a capacitor, then disconnecting the battery and pulling the plates farther apart. What changes in this situation? What stays the same?

Start by taking a large positively charged plate, with a potential of +8V at the plate.



We know that the potential drops off with distance, as in Figure 10.22a.

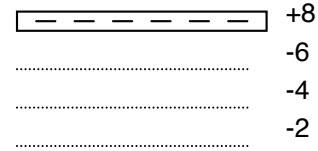
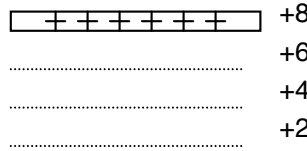

A large negatively charged plate, would have a potential of -8V at the plate, and the potential would increase with distance away, as in Figure 10.22b.

Figure 10.22a

Figure 10.22b

If we put the two plates close together, then the potential halos of the plates combine as in Figure 10.22c.

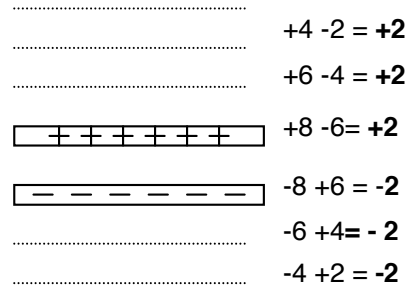

Figure 10.22c

PLATES AT 2 MM APART

1. $E =$ _____ Volts/meter
 = _____ Newtons/Coulomb

Next move the two plates twice as far apart. This changes the potential values of the two plates, since the potential halo values are different at different distances from the plate.

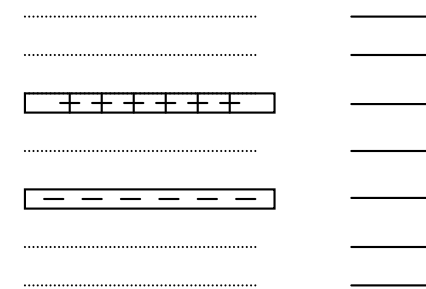

Figure 10.22d

PLATES AT 4 MM APART

2. Fill in the new potential values by combining the potentials due to each plate on Figure 10.22d.

3. How does the new potential difference between the plates compare with the original potential difference?

4. Look at the change of potential with distance. Divide the new potential difference by the new (doubled) distance to get the new value of the electric field. How does this value compare with the field at 2 mm separation?

You probably found that the value for the electric field is the same for each situation.

The increase in potential difference is just compensated for in the calculation for field strength by the increase in distance between the plates.

What about the energy stored between the plates? Since the plates are now twice as far apart, the volume of the space occupied by the field has been doubled, while the magnitude of the field stayed the same.

5. The total energy stored in the field is therefore how many times the energy stored before the plates were moved apart?

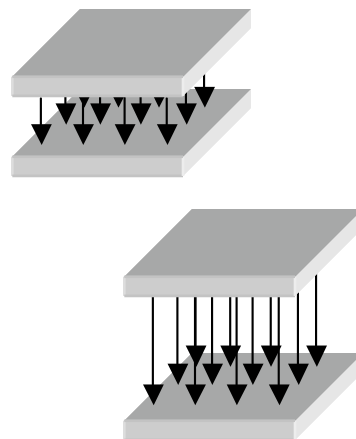

Figure 10.22e
SEPARATING CAPACITOR
PLATES

This energy had to come from somewhere. The plates are oppositely charged, and each plate exerts a force on the other. In order to separate the plates, some external force must do work on the plates, just as you had to do work on the charged foam and acrylic plates to pull them apart. In fact, if the plates of a capacitor were not held apart, they would pull together as the capacitor was charged.

SUMMARY EXERCISE

1. Investigation of the conditions that trigger a spark jumping shows that neither potential difference nor distance alone causes a spark. What is the condition that causes a spark?
2. What is the relationship between the flow rate of charge in a resistor and the electric field strength in a resistor?
3.
 - a. What device can be used to map the patterns of electric field near charged objects?
 - b. In terms of pushes and pulls, how does it work?
 - c. How does it indicate the direction of the electric field?
4. How are the directions of the electric field lines related to the lines of equal electric potential in the potential halo?
5. What is the equation that relates the electric force on a charge to the strength of the electric field where the charge is located? In this equation, what are the units of electric force, electric field strength and electric charge?
6. In a certain region of space there is an electric field that points east. What would be the direction of the electric force on a small negative charge placed in that location?
7. What is the experimental evidence that indicates energy is stored in the electric field between two oppositely charged plates that are separated?

8. A capacitor has plate area A and its plates are separated by a distance d . Write an equation to find the energy stored in a capacitor which includes the dimensions of the capacitor, the strength of the electric field in the capacitor and the characteristics of the insulating material between the plates? For each symbol in the equation give the name of the physical quantity it represents.