

## Math 1010 Final Exam Review

Solve the equation.

1)  $6x - (5x - 1) = 2$

2)  $-8b - 10 = -7 - 6b$

Find the slope of the line through the given pair of points.

3)  $(-9, -8)$  and  $(4, 9)$

Write the equation in slope-intercept form.

4)  $3x - 6y = 2$

Sketch the graph of the linear equation below.

5)  $2x - 5y = -15$

Find the midpoint of the segment with the given endpoints.

6)  $(5, 3)$  and  $(2, 7)$

Decide whether the pair of lines is parallel, perpendicular, or neither.

7)  $3x - 2y = -9$  and  $2x + 3y = -3$

For the compound inequality, give the solution set in both graph and interval notation.

8)  $x - 2 > 2$  or  $x + 3 < 1$

Solve the equation. Give your answer in set notation.

9)  $|6m + 5| = 6$

Solve the inequality and give the solution in graph and interval notation.

10)  $5 | 9x + 1 | + 3 < 23$

Simplify the expressions.

11)  $(-4p)^2 (-4p)^6$

12)  $\left( \frac{3p^3v^4}{s^4} \right)^2$

Perform the indicated operations below.

13)  $(3p - 1)(9p^2 + 3p + 1)$

14)  $(-6x^3 + 9x^2 + 4) - (-5x^3 + 2x - 5)$

15)  $(x^2 + 2x - 63) \div (x + 9)$

Factor the polynomials completely.

16)  $125x^3 + 27$

17)  $24m^7 - 20m^5 - 28m^3$

18)  $x^2 + 16x + 64$

Solve the system by graphing.

19)  $x - y = 6$

$x + y = 8$

Solve the system by either substitution or elimination.

20)  $x - 6y = 24$

$-7x - 7y = -21$

Solve the application problems below.

21) Jill is 20 kilometers away from Joe. Both begin to walk toward each other at the same time. Jill walks at 2.5 km/hr. They meet in 5 hours. How fast is Joe walking?

22) A bank teller has some five-dollar bills and some twenty-dollar bills. The teller has 5 more of the twenties. The total value of the money is \$775. Find the number of five-dollar bills that the teller has.

23) Mardi received an inheritance of \$70,000. She invested part at 12% and deposited the remainder in tax-free bonds at 8%. Her total annual income from the investments was \$ 8000. Find the amount invested at 12%.

24) How many liters of a 40% alcohol solution must be mixed with 20 liters of a 90% solution to get a 60% solution?

25) A small rocket is fired straight upward from the ground with an initial velocity of 400 feet per second. If the acceleration due to gravity is  $-32 \text{ ft/sec}^2$ , how long will it take the rocket to reach a height of 2500 feet? Use the formula:  $s = \frac{1}{2} a t^2 + v_0 t + s_0$ .

$$36) 2n^2 = -10n - 7$$

$$37) \frac{x}{16} - \frac{3}{8} = \frac{x-8}{8}$$

$$38) \frac{-5x}{2x+12} = \frac{2x}{4x+24} + \frac{6x-1}{x+6}$$

$$39) 3^x = 81$$

$$40) 4(1+2x) = 64$$

$$41) \log_3 x = 2$$

$$42) \log_{125} x = \frac{1}{3}$$

Simplify the radicals. Assume that all variables represent positive real numbers.

$$26) \sqrt[3]{9x} \cdot \sqrt[3]{49x}$$

$$27) \sqrt[3]{1000x^4y^5}$$

Perform the operations with radicals. Assume that all variables represent positive real numbers.

$$28) \sqrt{5x} + 7\sqrt{80x} + 2\sqrt{180x}$$

$$29) (\sqrt{3x} + 3)(\sqrt{7x} - 3)$$

$$30) \frac{3}{9 - \sqrt{2}}$$

Rewrite the equation in function notation.  $y$  is the dependent variable.

$$31) 5x - 6y = 5$$

State whether the relations in below are a function by answering "yes" or "no".

$$32) \{(-1, 7), (1, -9), (4, -9), (7, -5), (10, -3)\}$$

33)

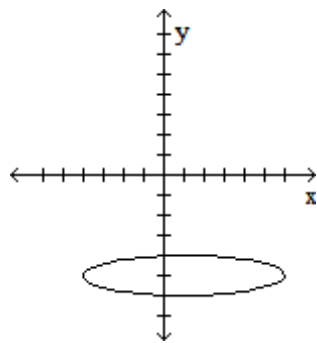

Solve the equations using any method.

$$34) \sqrt{8q+9} = 9$$

$$35) x^2 + 5x - 24 = 0$$

Solve the equations by completing the square.

$$43) x^2 + 8x = 7$$

$$44) x^2 + x + 5 = 0$$

Use the discriminant to determine whether the equation has two rational solutions, one rational solution, two irrational solutions, or two nonreal complex solutions. Do not actually solve.

$$45) v^2 + 7v + 1 = 0$$

$$46) w^2 - 2w + 8 = 0$$

What is the vertex of the equation below?

$$47) y = x^2 + 4x + 13$$

Graph the parabolas below. Also state the vertex, axis of symmetry, domain and range of the graph.

$$48) f(x) = 2x^2 - 2x - 5$$

$$49) y = -x^2 - 4$$

Evaluate the functions for the specified values.

$$50) \text{ Find } f(4) \text{ when } f(x) = x^2 - 4x + 2.$$

$$51) \text{ Find } f(-4) \text{ when } f(x) = 5x^2 + 2x + 5.$$

For the given pair of functions, find the requested function.

52) Find  $(f - g)(x)$  for:

$$f(x) = 4x - 3 \text{ and } g(x) = -9x + 9$$

53) Find  $(fg)(x)$  for:

$$f(x) = 4x + 2 \text{ and } g(x) = -2x - 8$$

54) Find  $\left(\frac{f}{g}\right)(x)$  and state any  $x$ -values that are not in the domain of the quotient function for:

$$f(x) = x^2 + 9x + 20 \text{ and } g(x) = x + 5.$$

55) Find  $(f \circ g)(x)$  for:

$$f(x) = x + 7 \text{ and } g(x) = 8x - 2$$

Perform the indicated operations with complex numbers.

56)  $(3 - 4i) + (6 + 7i)$

57)  $(8 - 3i)(3 + 2i)$

58)  $\frac{6 + 2i}{9 - 3i}$

Find the power of  $i$ .

59)  $i^{21}$

Determine whether or not the function is one-to-one.

60)

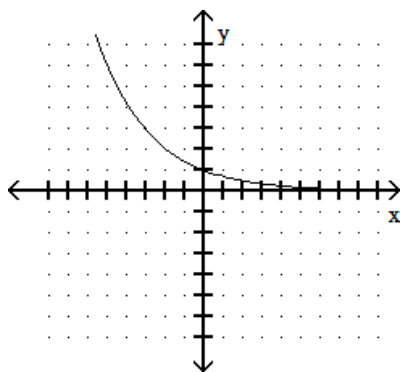

Determine whether or not the function is one-to-one.

61)

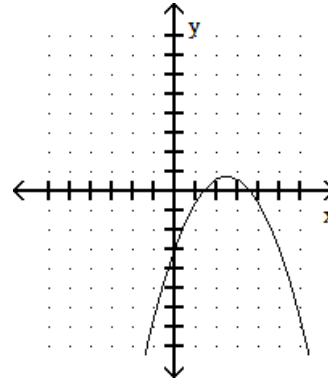

Write the rational expressions in lowest terms.

62)  $\frac{2x + 2}{10x^2 + 16x + 6}$

63)  $\frac{y^2 + 8y + 12}{y^2 + 14y + 48}$

Perform the indicated operations with the rational expressions below.

64)  $\frac{2p - 2}{p} \cdot \frac{7p^2}{4p - 4}$

65)  $\frac{8r - 24s}{3r - 6s} \div \frac{12s - 4r}{2r - 4s}$

66)  $\frac{7x + 7}{x} + \frac{3x - 5}{7x}$

67)  $\frac{4x}{x + 6} + \frac{2}{x - 6}$

Simplify the complex fraction.

68)  $\frac{\frac{2m^7n^2}{5m}}{\frac{9m^3n^8}{4n^4}}$

Find the inverse of the function below.

69)  $f(x) = 8x + 5$

Write in logarithmic form.

70)  $2^3 = 8$

Write in exponential form.

71)  $\log_{14} 1 = 0$

Choose the correct graph of the function.

72)  $f(x) = 3^x$

A)

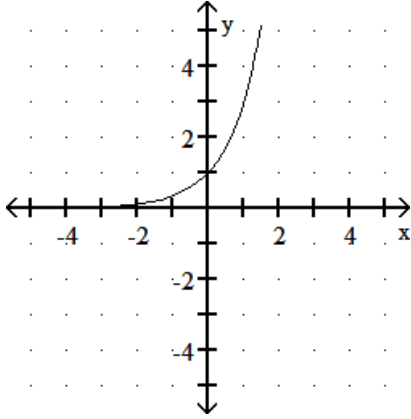

B)

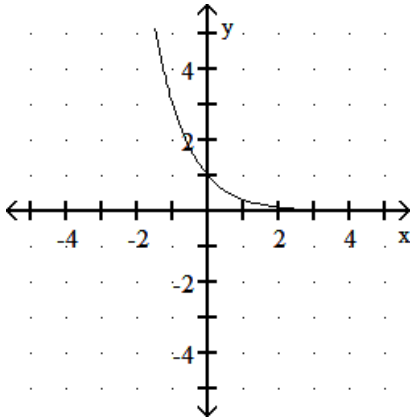

C)

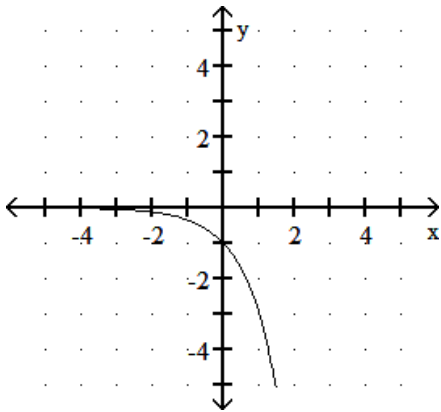

D)

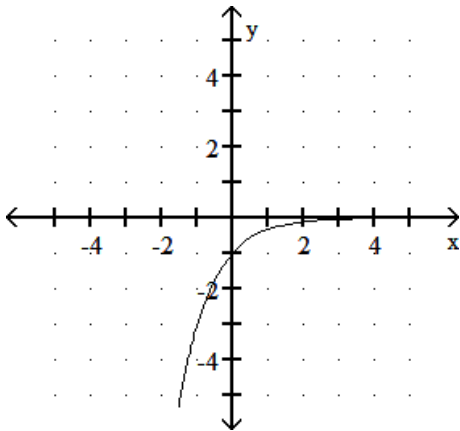

73)  $f(x) = \left(\frac{1}{4}\right)^x$

A)

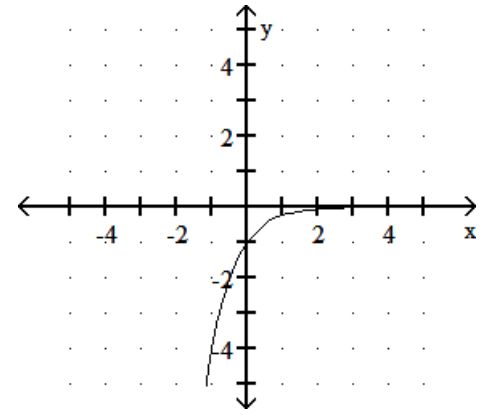

B)

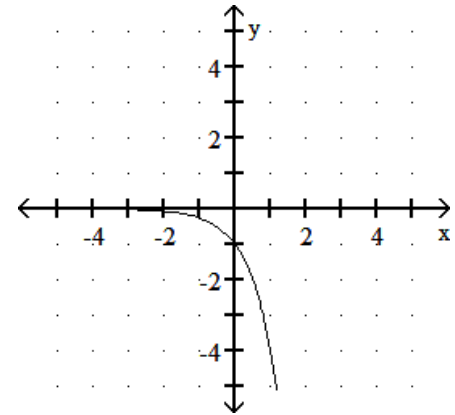

C)

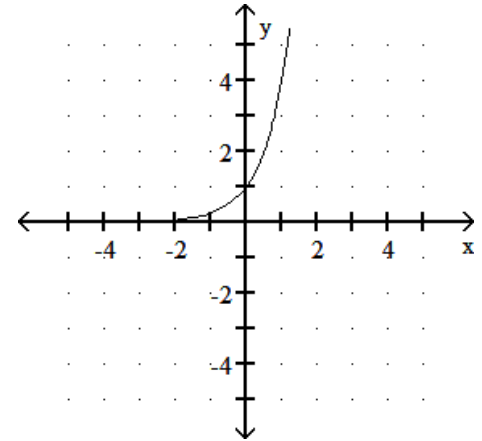

D)

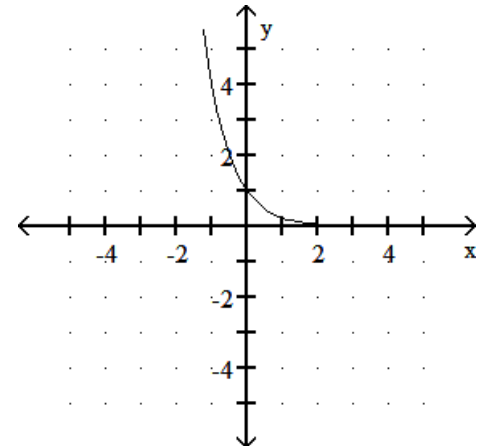

Choose the correct graph of the given functions below.

74)  $y = \log_4 x$

A)

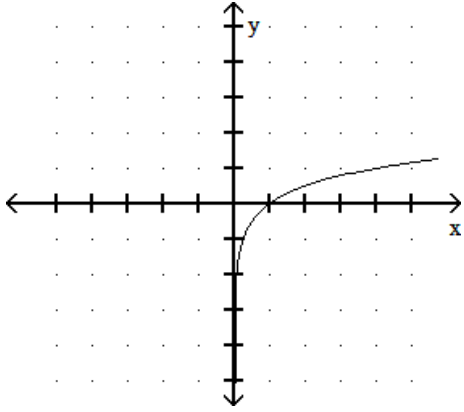

B)

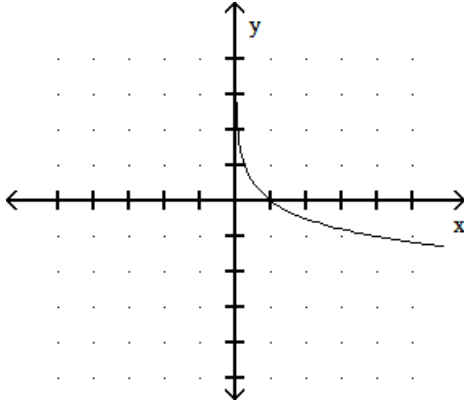

C)

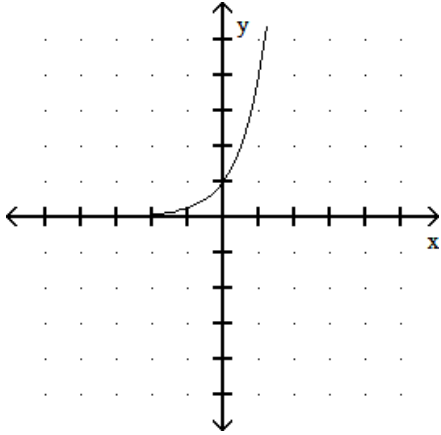

D)

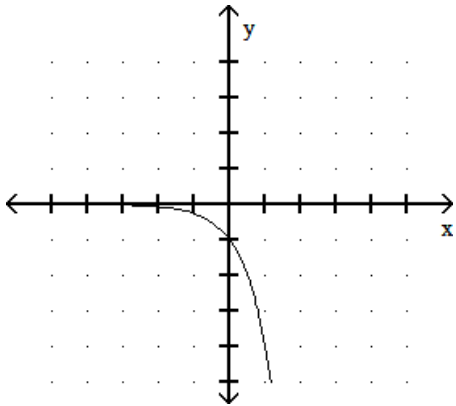

75)  $y = \log_{1/8} x$

A)

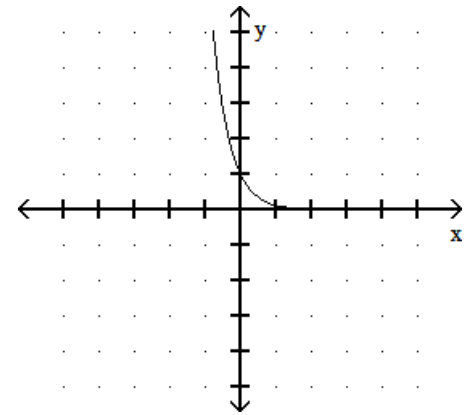

B)

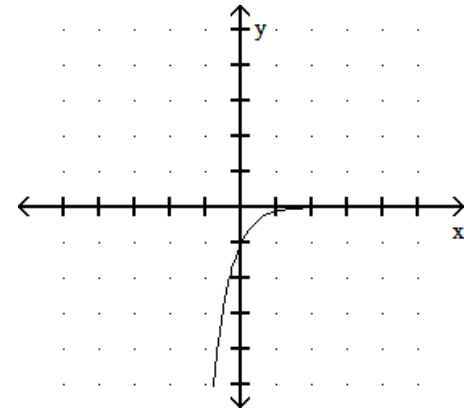

C)

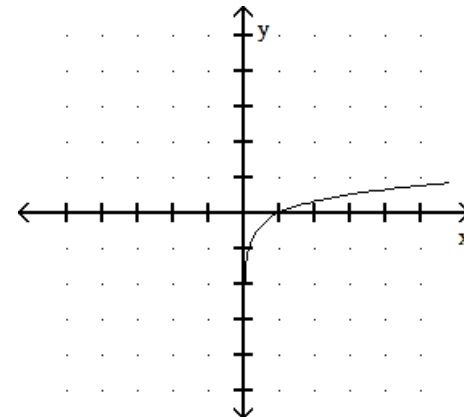

D)

