

Math 1010 - Intermediate Algebra - Practice Problems for the Final Exam

Perform the indicated operation.

1) $(7x - 11y)^2$

A) $49x^2 - 154xy + 121y^2$

C) $49x^2 + 121y^2$

B) $7x^2 + 121y^2$

D) $7x^2 - 154xy + 121y^2$

1) _____

Identify the graph of the equation as a parabola, circle, ellipse, or hyperbola.

2) $(x - 2)^2 = 64 - y^2$

A) Ellipse

B) Hyperbola

C) Circle

D) Parabola

2) _____

Solve the equation.

3) $3r^2 - 5r - 2 = 0$

A) $\left\{\frac{1}{5}, -\frac{1}{3}\right\}$

B) $\{-3, 2\}$

C) $\left\{-\frac{1}{3}, 3\right\}$

D) $\left\{-\frac{1}{3}, 2\right\}$

3) _____

Graph the inequality or compound inequality.

4) $y \geq -2x - 1$ and $x - y \geq -1$

4) _____

A)

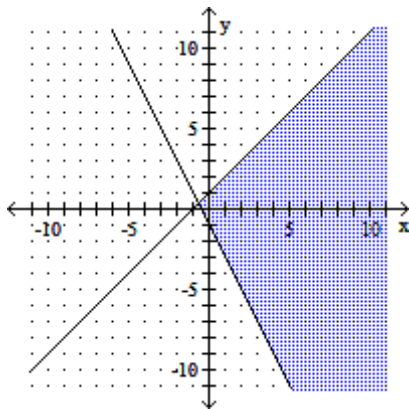

B)

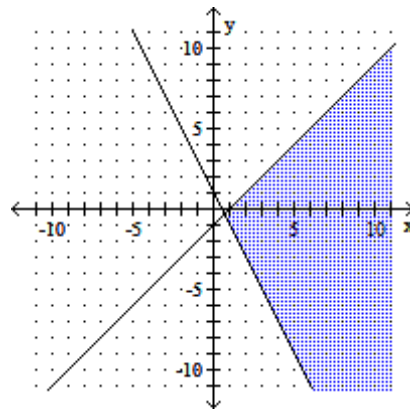

C)

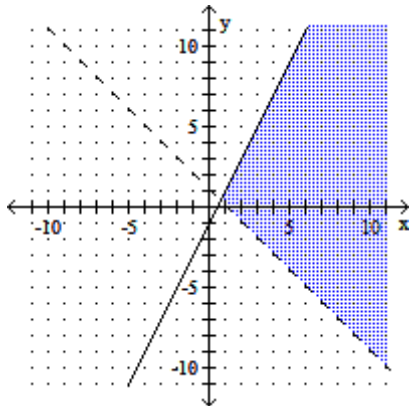

D)

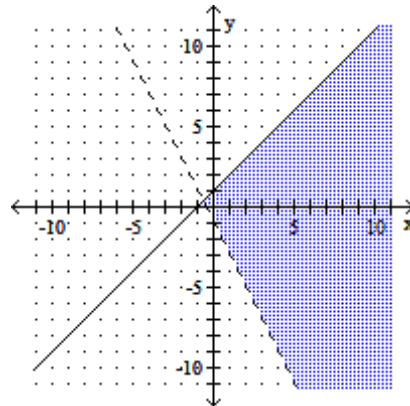

Solve the equation.

5) $\log_3(x - 2) + \log_3(x - 8) = 3$

A) $x = 11$

B) $x = 12$

C) $x = -1$

D) $x = 11, x = -1$

5) _____

Simplify. Assume that all variables represent positive real numbers.

6) $(3 - 2\sqrt{5})^2$

A) $9 - 4\sqrt{5}$

B) $9 + 4\sqrt{5}$

C) $29 + 12\sqrt{5}$

D) $29 - 12\sqrt{5}$

6) _____

Multiply or divide. Write the answer in lowest terms.

7) $\frac{3(p-1)}{p} \div \frac{8(p-1)}{4p^2}$

A) $\frac{3p}{2}$

B) $\frac{12p^3 - 12p^2}{8p^2 - 8p}$

C) $\frac{2}{3p}$

D) $\frac{24p^2 + 48p + 24}{4p^3}$

7) _____

Solve the absolute value equation or inequality. Give the solution set in interval form.

8) $|-3x - 6| - 5 < -1$

A) $\left(-\frac{10}{3}, -\frac{2}{3}\right)$

B) \emptyset

C) $\left(-\infty, -\frac{10}{3}\right) \cup \left(-\frac{2}{3}, \infty\right)$

D) $\left(-\infty, -\frac{10}{3}\right)$

8) _____

Add or subtract as indicated. Write your answer in the form $a + bi$.

9) $[(6 + 9i) - (4 + 10i)] - (10 - 4i)$

A) $-8 + 15i$

B) $20 + 3i$

C) $-8 + 3i$

D) $20 + 15i$

9) _____

Simplify. Assume that all variables represent positive real numbers.

10) $\sqrt{24} + 6\sqrt{150} - 3\sqrt{216}$

A) $-14\sqrt{6}$

B) $-150\sqrt{6}$

C) $27\sqrt{6}$

D) $14\sqrt{6}$

10) _____

Solve the equation. Give the exact solution.

11) $4^x = \frac{1}{256}$

A) $\{4\}$

B) $\{-4\}$

C) $\left\{\frac{1}{64}\right\}$

D) $\left\{\frac{1}{4}\right\}$

11) _____

Find the center and radius of the circle.

12) $x^2 + y^2 + 2x - 14y + 14 = 0$

A) $(-1, 7); r = 6$

B) $(1, -7); r = 36$

C) $(7, -1); r = 6$

D) $(-7, 1); r = 36$

12) _____

Solve the problem.

13) A ladder is resting against a wall. The top of the ladder touches the wall at a height of 15 ft. Find the length of the ladder if the length is 5 ft more than its distance from the wall.

A) 25 ft

B) 20 ft

C) 30 ft

D) 15 ft

13) _____

14) An investment broker invests \$109,800 in real estate and earns 2% per year on the investment. How much money is earned per year?

A) \$549,000

B) \$21,960

C) \$2196

D) \$5,490,000

14) _____

Graph the given logarithmic function.

15) $y = \log_{1/8} x$

15) _____

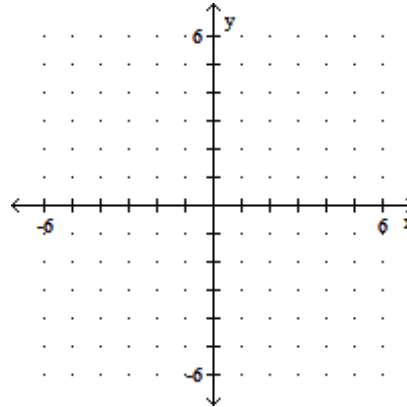

Solve the problem.

- 16) Find the measure of an angle, if its supplement measures 58° more than twice its complement. 16) _____
 A) 116° B) 68° C) 58° D) 32°

- 17) An express train and a local train both leave Gray's Lake at 3 P.M. and head for Chicago 50 miles away. The express travels twice as fast as the local and arrives 1 hour ahead of the local. Find the speed of each train. 17) _____
 A) Express: 60 mph; local: 30 mph
 B) Express: 25 mph; local: 12.5 mph
 C) Express: 50 mph; local: 25 mph
 D) Cannot be determined without more information

Add or subtract. Write the answer in lowest terms.

- 18) $\frac{4x}{x+6} + \frac{3}{x-6}$ 18) _____
 A) $\frac{4x+3}{(x+6)(x-6)}$ B) $\frac{4x^2-21x+18}{x^2+12x+36}$ C) $\frac{4x^2-21x+18}{x^2-36}$ D) $\frac{4x^2-21x+18}{x^2-12x+36}$

Solve the problem.

- 19) From a point on a straight road, two cars are driven in opposite directions, one at 48 miles per hour and the other at 58 miles per hour. In how many hours will they be 424 miles apart? 19) _____
 A) 4 hours B) 3 hours
 C) Not enough information D) 5 hours

Simplify.

- 20) i^{21} 20) _____
 A) -1 B) 1 C) -i D) i

Solve the compound inequality.

- 21) $-6 \leq 3x + 6$ and $2x + 9 < 9$ 21) _____
 A) $[-4, 0]$ B) $(-4, 0]$ C) $(-4, 0)$ D) $[-4, 0]$

Graph the parabola. Identify the vertex, axis, domain and range.

22) $x = (y + 5)^2 + 4$

22) _____

- A) Vertex: (1, 1); Axis: $x = -5$;
Domain: $(-\infty, \infty)$; Range: $(-\infty, 4]$

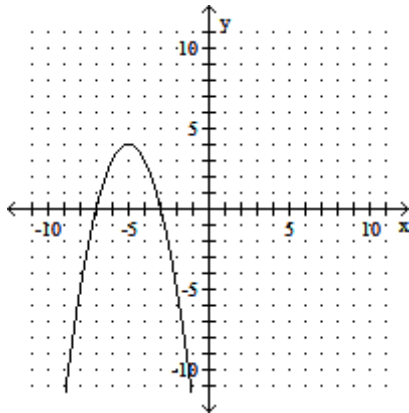

- B) Vertex: (4, -5); Axis: $y = -5$;
Domain: $(-\infty, 4]$; Range: $(-\infty, \infty)$

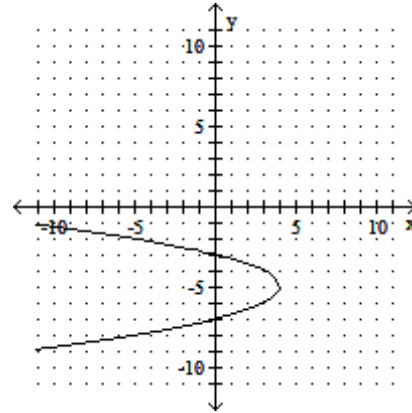

- C) Vertex: (4, -5); Axis: $y = -5$;
Domain: $[4, \infty)$; Range: $(-\infty, \infty)$

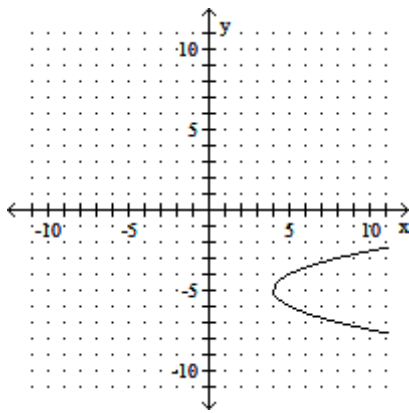

- D) Vertex: (-1, -5); Axis: $x = -5$;
Domain: $(-\infty, \infty)$; Range: $[4, \infty)$

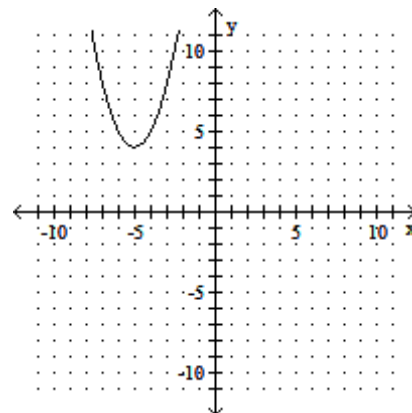

If the following defines a one-to-one function, find its inverse. If not, write "Not one-to-one."

23) $f(x) = 8x + 5$

23) _____

- A) Not one-to-one

B) $f^{-1}(x) = \frac{x - 5}{8}$

C) $f^{-1}(x) = \frac{x}{8} - 5$

D) $f^{-1}(x) = \frac{x + 5}{8}$

Solve the compound inequality.

24) $-3x \leq -9$ or $9x - 6 < 3x$

24) _____

- A) \emptyset

B) $[1, 3]$

C) $(1, 3)$

D) $(-\infty, 1) \cup [3, \infty)$

Find an equation of the line passing through the two points. Write the equation in standard form.

25) (1, -2) and (-2, 9)

25) _____

A) $3x - 11y = -93$

B) $11x + 3y = 5$

C) $-11x + 3y = 5$

D) $-3x + 11y = -93$

If the following defines a one-to-one function, find its inverse. If not, write "Not one-to-one."

26) $f(x) = -3x^2 - 2$

26) _____

A) Not one-to-one

B) $f^{-1}(x) = \sqrt{\frac{x+2}{-3}}$

C) $f^{-1}(x) = \frac{x+2}{-3}$

D) $f^{-1}(x) = \pm \sqrt{\frac{x+2}{-3}}$

Graph.

27) $16x^2 - 9y^2 = 144$

27) _____

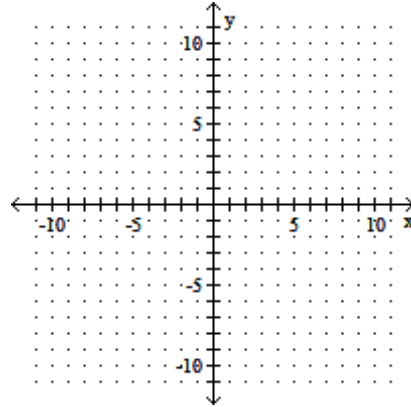

Find the equation of a circle satisfying the given conditions.

28) Center: $(-5, 9)$; radius: 5

28) _____

A) $(x + 9)^2 + (y - 5)^2 = 5$

B) $(x + 5)^2 + (y - 9)^2 = 25$

C) $(x - 5)^2 + (y + 9)^2 = 25$

D) $(x - 9)^2 + (y + 5)^2 = 5$

Solve the problem. Round your answer to the nearest tenth, when appropriate.

29) A rock falls from a tower that is 49 m high. As it is falling, its height is given by the formula

29) _____

$h = 49 - 4.9t^2$. How many seconds will it take for the rock to hit the ground ($h=0$)?

A) 490 sec

B) 3.2 sec

C) 6.6 sec

D) 7 sec

Simplify the expression. Assume that all variables represent positive real numbers.

30) $\frac{5^{3/4}x - 2^{2/3}y^{3/2}}{5 - 5^{4/4}x^{4/2}y^{1/4}}$

30) _____

A) $\frac{25y^{5/4}}{x^2}$

B) $\frac{25y^{5/8}}{x^4}$

C) $\frac{125y^{5/4}}{x^3}$

D) $\frac{25y^{5/4}}{x^3}$

Find the center and radius of the circle whose equation is given.

31) $x^2 + y^2 - 10x - 4y + 29 = 36$

31) _____

A) center: $(-2, -5)$; radius: 36

B) center: $(2, 5)$; radius: 6

C) center: $(-5, -2)$; radius: 36

D) center: $(5, 2)$; radius: 6

Simplify the expression. Assume that all variables represent positive real numbers.

32) $(-27)^{-2/3}$

32) _____

A) -9

B) $\frac{1}{9}$

C) 9

D) $-\frac{1}{9}$

Find an equation of the line, and write it in (a) slope-intercept form if possible and (b) standard form.

33) Through $(-6, 2)$; horizontal

A) (a) not possible
(b) $x = -6$

B) (a) $y = 2$
(b) $y = 2$

C) (a) not possible
(b) $x = -2$

D) (a) $y = 6$
(b) $y = 6$

33) _____

Graph the compound inequality.

34) $2x + y < 6$ or $3x - 2y > 5$

34) _____

A)

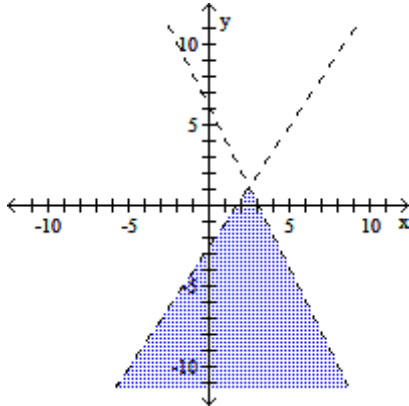

B)

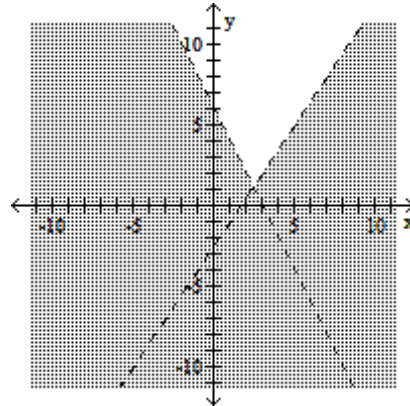

C)

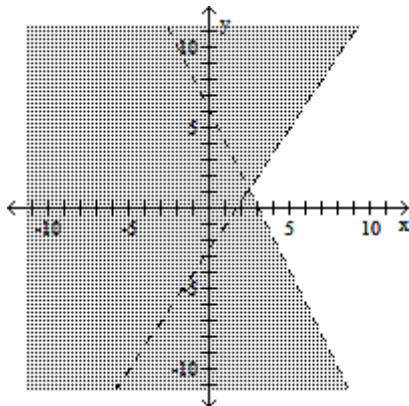

D)

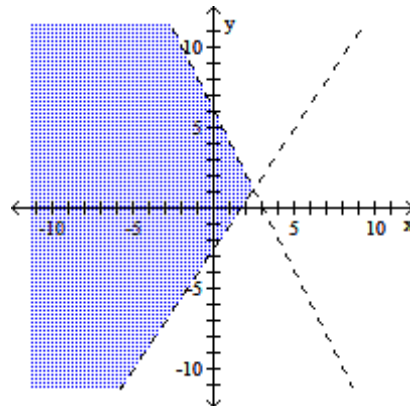

Write an equation for the line. Give the final answer in slope-intercept form.

35) Through $(1, -5)$ and $(-3, -8)$

A) $y = -\frac{6}{5}x - \frac{22}{5}$

B) $y = \frac{3}{4}x - \frac{23}{4}$

C) $y = -\frac{3}{4}x - \frac{23}{4}$

D) $y = \frac{6}{5}x - \frac{22}{5}$

35) _____

Find any values of the variable for which the rational expression is undefined. Write answer with \neq .

36) $\frac{x^2 - 4}{x^2 - 11x + 30}$

A) $x \neq 0$

B) $x \neq 2, x \neq -2$

C) $x \neq -5, x \neq -6$

D) $x \neq 5, x \neq 6$

36) _____

Use a formula to solve the problem.

37) A square plywood platform has a perimeter which is 6 times the length of a side, decreased by 14.

Find the length of a side.

A) 1

B) 7

C) 2

D) 9

37) _____

Multiply, then simplify the product. Assume that all variables represent positive real numbers.

38) $(3 - 2\sqrt{3})^2$

A) $21 + 12\sqrt{3}$

B) $9 + 4\sqrt{3}$

C) $21 - 12\sqrt{3}$

D) $9 - 4\sqrt{3}$

38) _____

Factor completely. If the polynomial is prime, say so.

39) $x^2 + 4$

A) $(x + 2)^2$

B) $(x + 2)(x - 2)$

C) $(x - 2)^2$

D) Prime

39) _____

40) $x^4 - 1$

A) $(x^2 - 1)(x + 1)(x - 1)$

B) $(x + 1)^2(x - 1)^2$

C) $(x^2 + 1)(x + 1)(x - 1)$

D) Prime

40) _____

Determine whether the relation defines y as a function of x . Give the domain.

41) $y = \sqrt{4x - 3}$

A) Not a function; domain: $\left[-\infty, \frac{3}{4}\right]$

B) Function; domain: $\left[\frac{3}{4}, \infty\right)$

C) Not a function; domain: $\left[\frac{3}{4}, \infty\right)$

D) Function; domain: $(-\infty, \infty)$

41) _____

Perform the indicated operation. Give answer in standard form.

42) $(4 + 5i)(9 + 4i)$

A) $56 + 29i$

B) $20i^2 + 61i + 36$

C) $16 + 61i$

D) $16 - 61i$

42) _____

Write the rational expression in lowest terms.

43) $\frac{y^2 + 2y - 15}{y^2 - 4y - 45}$

A) $-\frac{y^2 + 2y - 15}{y^2 - 4y - 45}$

B) $\frac{2y - 15}{-4y - 45}$

C) $\frac{2y - 1}{-4y - 3}$

D) $\frac{y - 3}{y - 9}$

43) _____

Solve the equation for the indicated variable.

44) $aS^2 + bS = c$, for S

A) $S = \frac{-b + \sqrt{b^2 - 4ac}}{2a}$

B) $S = \frac{-b + b^2 + 4ac}{2a}$

C) $S = \frac{-b + \sqrt{b^2 + 4ac}}{2a}$

D) $S = \frac{-b + b^2 - 4ac}{2a}$

44) _____

For the given pair of functions, find the requested function.

45) Let $f(x) = 2x^2 - 4x - 1$ and $g(x) = x - 1$; $(f \circ g)(x)$.

A) $2x^2 - 8x - 3$

B) $2x^2 - 6x - 3$

C) $2x^2 - 8x + 5$

D) $-8x^2 + 2x + 5$

45) _____

Find an equation of the line satisfying the conditions. Write the equation in slope-intercept form.

46) Through $(-3, 8)$; perpendicular to $-3x + 4y = -23$

A) $y = -\frac{3}{4}x + \frac{23}{4}$

B) $y = \frac{4}{3}x + 12$

C) $y = -\frac{4}{3}x + 4$

D) $y = \frac{3}{4}x + \frac{41}{4}$

46) _____

Solve the system by substitution or elimination. If a system is inconsistent or has dependent equations, say so.

47) $x + 8y = 41$

$3x + 7y = 55$

A) $\{(-9, 5)\}$

C) $\{(8, 5)\}$

B) $\{(9, 4)\}$

D) \emptyset ; inconsistent system

47) _____

Decide whether or not the ordered pair is a solution of the system.

48) $(-2, -1)$

$y + 2x = -5$

$x + y = -3$

A) Yes

B) No

48) _____

For the polynomial function, find the requested value.

49) $f(x) = 8x + 7$; $f(4)$

A) 25

B) 64

C) 15

D) 39

49) _____

Find the slope of the line.

50) $x = 10$

A) 10

B) 1

C) Undefined

D) 0

50) _____

Evaluate.

51) $\sqrt[3]{-216}$

A) -36

B) 6i

C) -6

D) 6

51) _____

Write the expression in the form $a + bi$.

52) $\frac{6 + 2i}{9 - 3i}$

A) $\frac{8}{15} + \frac{2}{5}i$

B) $\frac{5}{6} - \frac{1}{12}i$

C) $-\frac{48}{65} - \frac{36}{65}i$

D) $\frac{14}{15}$

52) _____

Express the radical in simplified form. Assume that all variables represent positive real numbers.

53) $-\sqrt[3]{125x^4y^5}$

A) $-5xy\sqrt[3]{xy^2}$

B) $5xy\sqrt[3]{xy^2}$

C) $-5xy\sqrt[3]{xy}$

D) $xy\sqrt[3]{xy^2}$

53) _____

Solve the system by substitution or elimination. If a system is inconsistent or has dependent equations, say so.

54) $x - 4y = 3$

$x = 5 + 4y$

A) $\{(3, 4)\}$

C) $\{(x, y) \mid x - 4y = 3\}$; dependent equations

B) $\{(3, 0)\}$

D) \emptyset ; inconsistent system

54) _____

Solve, giving the correct solution to four decimal places.

55) $8^x = 22$

A) $\{0.6700\}$

B) $\{2.0116\}$

C) $\{1.4865\}$

D) $\{2.7500\}$

55) _____

Graph the linear equation. Give the x- and y-intercepts.

56) $3x + y = -3$

56) _____

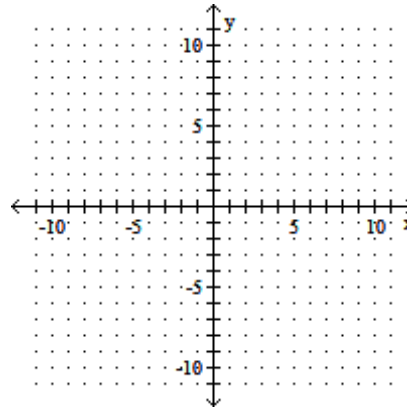

Write the number in scientific notation.

57) The earth is approximately 92,900,000 miles from the sun.

A) 9.29×10^7

B) 9.29×10^8

C) 9.29×10^6

D) 9.29×10^{-7}

57) _____

Evaluate the expression.

58) $5^{-1} + 2^{-1}$

A) $\frac{10}{7}$

B) $\frac{1}{3}$

C) $\frac{7}{10}$

D) 2

58) _____

Multiply or divide as indicated. Write the answer in lowest terms.

59) $\frac{2t^2 - 3t - 9}{3t^2 - 4t - 7} \cdot \frac{3t^2 + 11t - 42}{t^2 + 3t - 18}$

A) $\frac{(2t + 3)(t + 3)}{(t + 6)(3t - 7)}$

B) $\frac{2t + 3}{t - 1}$

C) $\frac{2t + 3}{t + 1}$

D) $\frac{(2t + 3)(t + 6)}{(t + 1)(t - 6)}$

59) _____

60) $\frac{z^2 + 15z + 54}{z^2 + 17z + 72} \div \frac{z^2 + 6z}{z^2 + 18z + 80}$

A) $\frac{z + 10}{z^2 + 8z}$

B) $z + 10$

C) $\frac{z + 10}{z}$

D) $\frac{z}{z^2 + 17z + 72}$

60) _____

Simplify. Write the answer using only positive exponents. Assume all variables represent nonzero numbers.

61) $\frac{(x^{-3})^{-7}(x^{-1}y)^2}{(xy^{-7})^2}$

A) $x^{21}y^{16}$

B) $x^{20}y^5$

C) $x^{42}y^{-12}$

D) $x^{17}y^{16}$

61) _____

Provide an appropriate response.

62) Which one of the following is the graph of a function?

62) _____

A)

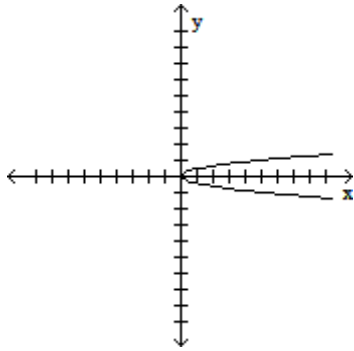

B)

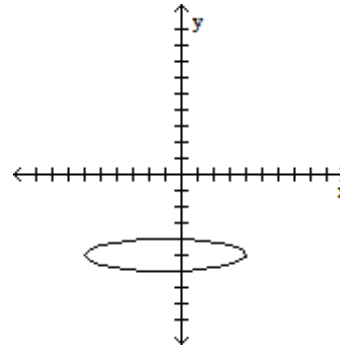

C)

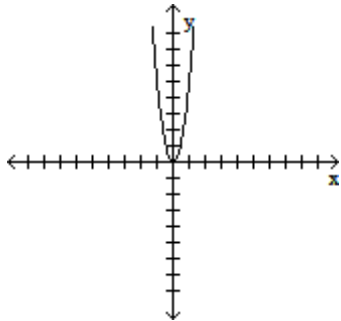

D)

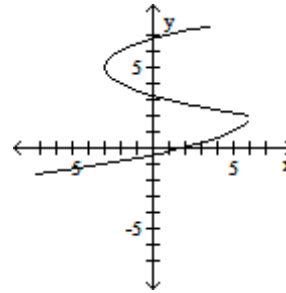

Evaluate the composition of functions.

63) Let $f(x) = 7x + 3$ and $g(x) = x + 6$. Find $(f \circ g)(4)$.

63) _____

A) 37

B) 41

C) 310

D) 73

Find the vertex of the parabola.

64) $f(x) = 2x^2 + 16x + 29$

64) _____

A) (3, 4)

B) (-3, -4)

C) (-4, -3)

D) (4, 3)

Solve the inequality. Write the solution set in interval notation and graph it.

65) $12x - 18 > 3(3x - 13)$

65) _____

A) $(-7, \infty)$

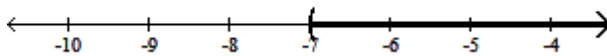

B) $[-7, \infty)$

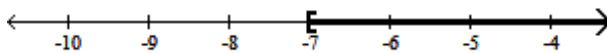

C) $(-\infty, -7)$

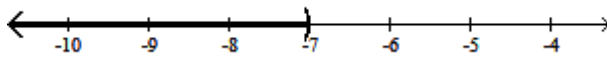

D) $(-\infty, -7]$

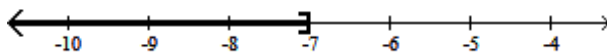

Solve by using the square root property.

66) $(3x + 6)^2 = 4$

A) $\left\{-\frac{4}{3}, -\frac{8}{3}\right\}$

B) $\left\{-\frac{4}{3}, 0\right\}$

C) $\left\{\frac{4}{3}, \frac{8}{3}\right\}$

D) $\left\{\frac{2}{3}\right\}$

66) _____

Solve the problem.

67) A woman has \$1.70 in dimes and nickels. She has 2 more dimes than nickels. How many nickels does she have?

A) 10 nickels

B) 8 nickels

C) 14 nickels

D) 12 nickels

67) _____

Determine whether the relation defines y as a function of x . Give the domain.

68) $y^2 = 3x$

A) Function; domain: $(-\infty, 0]$

B) Function; domain: $(-\infty, \infty)$

C) Not a function; domain: $[0, \infty)$

D) Not a function; domain: $(-\infty, 0]$

68) _____

Solve the equation.

69) $\log_{1/3} x = -4$

A) $\left\{\frac{1}{64}\right\}$

B) $\{81\}$

C) $\left\{\frac{1}{81}\right\}$

D) $\{64\}$

69) _____

70) $\frac{4}{x-4} + \frac{4}{2x-8} = 6$

A) $\{5\}$

B) $\{-3\}$

C) $\{1\}$

D) $\{60\}$

70) _____

Solve the problem.

71) A plane flies 500 miles with the wind and 320 miles against the wind in the same length of time. If the speed of the wind is 27 mph, what is the speed of the plane in still air?

A) 113 mph

B) 148 mph

C) 128 mph

D) 123 mph

71) _____

Identify the graph of the equation as a parabola, circle, ellipse, or hyperbola.

72) $9x^2 = 4y^2 + 36$

A) Circle

B) Parabola

C) Hyperbola

D) Ellipse

72) _____

Solve the problem.

73) Ron can mow the lawn in two hours more time than Paul. Working together they can mow the lawn in 3 hours. How long does it take each of them working alone? Round your answers to the nearest tenth of an hour, if necessary.

A) Paul: 4 hr
Ron: 8 hr

B) Paul: 8 hr
Ron: 4 hr

C) Paul: 5.2 hr
Ron: 7.2 hr

D) Paul: 7.2 hr
Ron: 5.2 hr

73) _____

Solve the equation for the indicated variable. (Leave \pm in your answer, when appropriate.)

74) $c^2 + d^2 + f^2 = g^2$, for c

A) $c = g^2 - d^2 - f^2$

B) $c = \pm\sqrt{g^2 - d^2 - f^2}$

C) $c = g - d - f$

D) $c = -g + d + f$

74) _____

Graph the inequality or compound inequality.

75) $8x + 5y > -2$

75) _____

A)

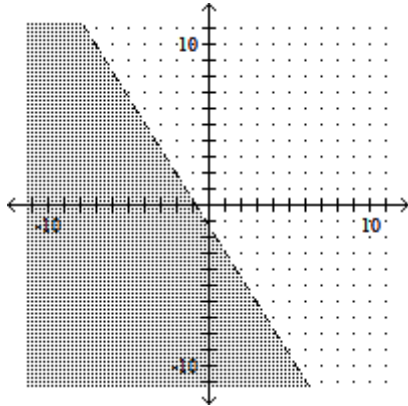

B)

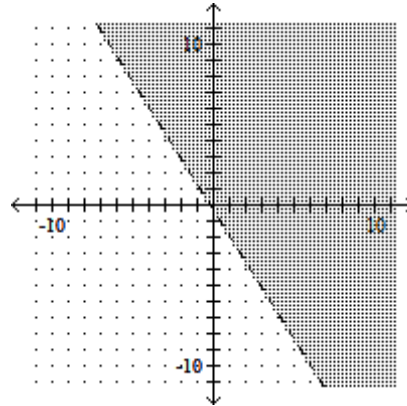

C)

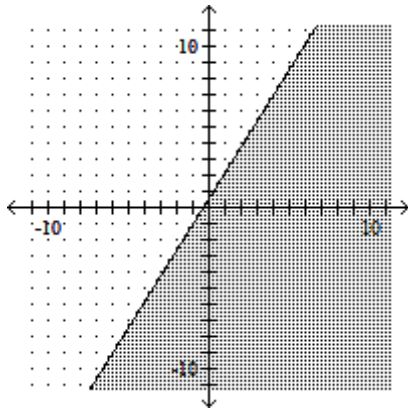

D)

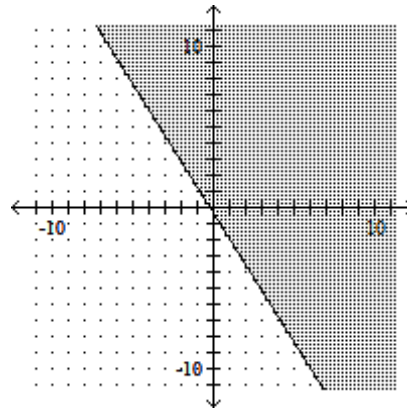

Solve the equation.

76) $x^2 - x = 6$

A) $\{-2, 3\}$

B) $\{2, 3\}$

C) $\{-2, -3\}$

D) $\{1, 6\}$

76) _____

Simplify. Assume that all variables represent positive real numbers.

77) $\frac{-20}{\sqrt{8} + \sqrt{3}}$

A) $4(\sqrt{8} - \sqrt{3})$

B) $-(\sqrt{8} - \sqrt{3})$

C) $-4(\sqrt{8} - \sqrt{3})$

D) $-4(\sqrt{8} + \sqrt{3})$

77) _____

Solve the equation.

78) $\frac{5}{m-2} - \frac{8}{m+2} = \frac{2}{m^2-4}$

A) $\{-8\}$

B) $\{8, -8\}$

C) $\{8\}$

D) \emptyset

78) _____

Solve the problem.

79) John and Tony start from Grays lake at the same time and head for a town 10 miles away. John walks twice as fast as Tony and arrives 3 hours before Tony. Find how fast each walks.

79) _____

- A) Tony: $\frac{5}{3}$ mph; John: $\frac{10}{3}$ mph
- B) Tony: $\frac{3}{5}$ mph; John: $\frac{6}{5}$ mph
- C) Tony: 3 mph; John: 6 mph
- D) Cannot be determined without more information

Graph the linear equation. Give the x- and y-intercepts.

80) $x + 1 = 0$

80) _____

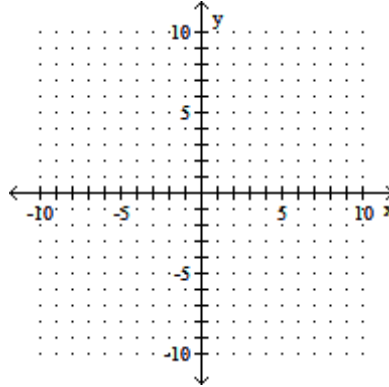

Solve the problem.

81) The percent increase for in-state tuition at a certain public university during the years 1991 through 1999 can be modeled by the quadratic function defined by

81) _____

$$f(x) = 0.156x^2 - 2.06x + 10.1,$$

where $x = 1$ represents 1991, $x = 2$ represents 1992, and so on.

(i) Based on this model, by what percent (to the nearest tenth) did tuition increase in 1998?

(ii) In what year was the minimum tuition increase? (Round down to the nearest year.) To the nearest tenth, by what percent did tuition increase that year?

- | | | | |
|--------------|--------------|--------------|---------------|
| A) (i) 3.6%; | B) (i) 3.3%; | C) (i) 4.2%; | D) (i) 46.3%; |
| (ii) 1996; | (ii) 1996; | (ii) 1995; | (ii) 1997; |
| 3.4% | 3.4% | 3.7% | 32.2% |

Identify the graph of the equation as a parabola, circle, ellipse, or hyperbola.

82) $9x^2 + 16y^2 = 144$

82) _____

- A) Parabola
- B) Hyperbola
- C) Ellipse
- D) Circle

Solve the equation.

83) $\frac{2}{2x} - \frac{2}{x+2} = 1$

83) _____

- A) $\left\{ \frac{3 + \sqrt{17}}{2}, \frac{3 - \sqrt{17}}{2} \right\}$
- B) \emptyset
- C) $\left\{ \frac{-3 + \sqrt{17}}{2}, \frac{-3 - \sqrt{17}}{2} \right\}$
- D) $\left\{ \frac{-5 + \sqrt{17}}{2}, \frac{-5 - \sqrt{17}}{2} \right\}$

84) $\frac{4x - 2}{5} = \frac{6x + 5}{10}$

84) _____

A) $\frac{1}{14}$

B) $\frac{9}{2}$

C) $\frac{1}{2}$

D) $\frac{9}{14}$

Solve the problem.

85) Thompson's Hardware spent \$75,910 this year on advertising alone. If total sales were \$886,600, what percent of total sales was spent on advertising? Round to the nearest tenth of a percent, if necessary.

85) _____

A) 11.7%

B) 117%

C) 0.9%

D) 8.6%

Solve the inequality and graph the solution set.

86) $-10x + 5(x - 6) \geq 7x - (2 + 2x) - 68$

86) _____

A) $(4, \infty)$

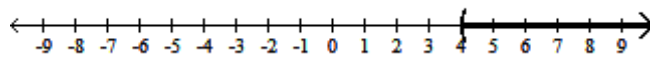

B) $(-\infty, 4)$

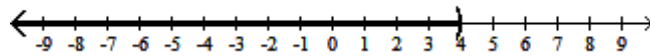

C) $(-\infty, 4]$

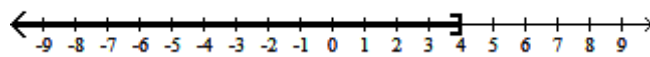

D) $[4, \infty)$

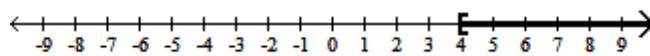

Solve the problem.

87) Mardi received an inheritance of \$70,000. She invested part at 12% and deposited the remainder in tax-free bonds at 8%. Her total annual income from the investments was \$8000. Find the amount invested at 12%.

87) _____

A) \$30,000

B) \$59,000

C) \$60,000

D) \$62,000

88) In the previous baseball season, team A won the most games of any major league team. Team A won 134 less than three times as many games as they lost. They played 162 regular-season games. How many wins and losses did team A have?

88) _____

A) Wins: 88; losses: 75

B) Wins: 89; losses: 73

C) Wins: 86; losses: 76

D) Wins: 88; losses: 74

Solve the equation.

89) $6 - (x - 2) = -6x + 5(x + 10)$

89) _____

A) $\left\{ \frac{42}{0} \right\}$

B) $\{21\}$

C) {all real numbers}

D) \emptyset

90) $7x^2 + 9x + 4 = 0$

A) $\left\{ \frac{-9 + \sqrt{31}}{14}, \frac{-9 - \sqrt{31}}{14} \right\}$

C) $\left\{ \frac{-9 + i\sqrt{31}}{14}, \frac{-9 - i\sqrt{31}}{14} \right\}$

B) $\left\{ \frac{9 + \sqrt{31}}{14}, \frac{9 - \sqrt{31}}{14} \right\}$

D) $\left\{ \frac{9 + i\sqrt{31}}{14}, \frac{9 - i\sqrt{31}}{14} \right\}$

90) _____

Solve the equation.

91) $\frac{x}{16} - \frac{3}{8} = \frac{x-8}{8}$

A) {10 }

B) {2 }

C) {5 }

D) {13 }

91) _____

Solve the problem.

92) A plane flies 420 miles with the wind and 340 miles against the wind in the same length of time. If the speed of the wind is 22 mph, what is the speed of the plane in still air?

A) 209 mph

B) 199 mph

C) 214 mph

D) 234 mph

92) _____

If the following defines a one-to-one function, find its inverse. If not, write "Not one-to-one."

93) $f(x) = x^3 - 9$

A) Not one-to-one

B) $f^{-1}(x) = x + 9$

C) $f^{-1}(x) = \sqrt[3]{x+9}$

D) $f^{-1}(x) = \pm\sqrt[3]{x+9}$

93) _____

Sketch the graph of the parabola.

94) $y = 2(x - 2)^2 - 1$

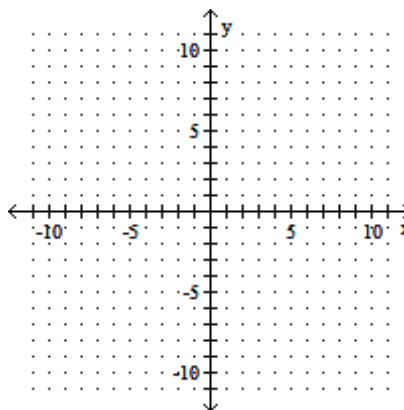

94) _____

Solve the problem.

95) Jill is 9 km away from Joe. Both begin to walk toward each other at the same time. Jill walks at 2.5 km per hour. If they meet in 2 hours, how fast is Joe walking?

A) 2 km per hour

B) 3 km per hour

C) 2.5 km per hour

D) 4 km per hour

95) _____

Factor completely. If the polynomial is prime, say so.

96) $16y^4 - 56y^3 - 32y^2$

A) $8y^2(2y + 1)(y - 4)$

B) $y^2(16y - 8)(y + 4)$

C) $8y^2(2y - 1)(y + 4)$

D) Prime

96) _____

Solve the equation.

97) $5x + \sqrt{x + 20} = 5 + 3x$

97) _____

A) $\{5, \frac{1}{4}\}$

B) $\{25\}$

C) $\{-5, -\frac{1}{4}\}$

D) $\{10\}$

98) $25x^4 - 61x^2 + 36 = 0$

98) _____

A) $\{-1, -\frac{5}{6}\}$

B) $\{-1, -\frac{5}{6}, \frac{5}{6}, 1\}$

C) $\{1, \frac{6}{5}\}$

D) $\{-\frac{6}{5}, -1, 1, \frac{6}{5}\}$

Solve the problem.

99) How many liters of a 40% alcohol solution must be mixed with 20 liters of a 90% solution to get a 60% solution?

99) _____

A) 30 L

B) 50 L

C) 3 L

D) 5 L

Find the center and radius of the circle whose equation is given. Graph the circle.

100) $(x + 5)^2 + (y + 3)^2 = 4$

100) _____

A) center: $(5, 3)$; radius: 2

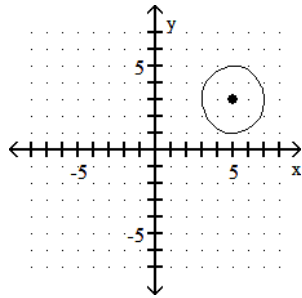

B) center: $(-5, -3)$; radius: 2

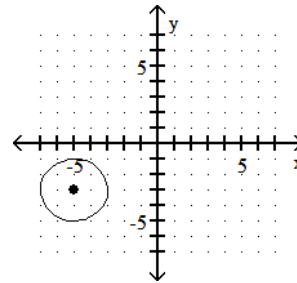

C) center: $(-5, -3)$; radius: 4

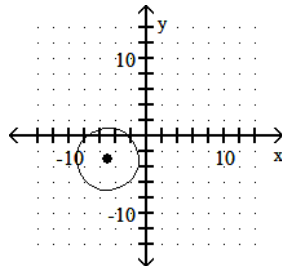

D) center: $(5, 3)$; radius: 4

