

## SECTIONS 2.4 & 2.5 JOURNAL NOTES

### STEPS TO SOLVING AN APPLIED PROBLEM

- **READ** the problem carefully until you understand what is given and what is to be found.
- **ASSIGN A VARIABLE** to represent the unknown value, using diagrams or tables as needed. Write down what the variable represents. If necessary, express any other unknown values in terms of the variable.
- **WRITE AN EQUATION** using the variable expression(s).
- **SOLVE** the equation.
- **STATE THE ANSWER.** Does it seem reasonable?
- **CHECK** the answer in the words of the *original* problem.

### COMPLEMENTARY AND SUPPLEMENTARY ANGLES

- **Right angle:** An angle that measures  $90^\circ$ .
- **Complementary angles:** Two angles whose sum is  $90^\circ$ .
- **Supplementary angles:** Two angles whose sum is  $180^\circ$

### CONSECUTIVE INTEGERS

- **Two consecutive integers:** Examples 3, 4    -5, -4  
✓ Use:  $x, x + 1$
- **Two consecutive *even* integers:** Examples 6, 8    -12, -10  
✓ Use:  $x, x + 2$
- **Two consecutive *odd* integers:** Examples: 5, 7    -23, -21  
✓ Use:  $x, x + 2$

### VERTICAL ANGLES

- Have equal measure. Set 1 = 2.

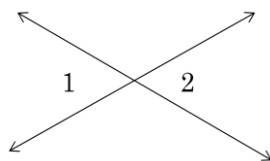

# Triangles and Angles

## Right Triangle

Triangle has one  $90^\circ$  (right) angle.

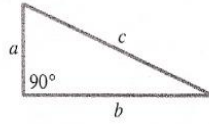

## Pythagorean Formula (for right triangles)

$$a^2 + b^2 = c^2$$

## Right Angle

Measure is  $90^\circ$ .

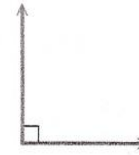

## Isosceles Triangle

Two sides are equal.  
 $AB = BC$



## Straight Angle

Measure is  $180^\circ$ .



## Equilateral Triangle

All sides are equal.  
 $AB = BC = CA$

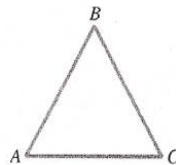

## Complementary Angles

The sum of the measures of two complementary angles is  $90^\circ$ .

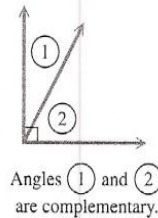

## Sum of the Angles of Any Triangle

$$A + B + C = 180^\circ$$

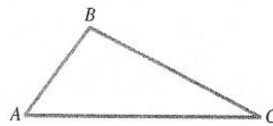

## Supplementary Angles

The sum of the measures of two supplementary angles is  $180^\circ$ .

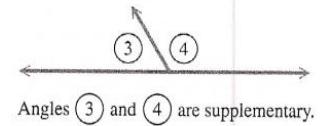

## Similar Triangles

Corresponding angles are equal; corresponding sides are proportional.

$$A = D, B = E, C = F$$

$$\frac{AB}{DE} = \frac{AC}{DF} = \frac{BC}{EF}$$

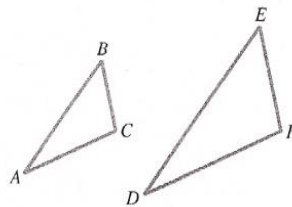

## Vertical Angles

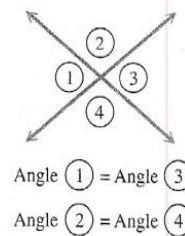

Vertical angles have equal measures.

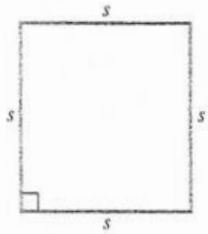
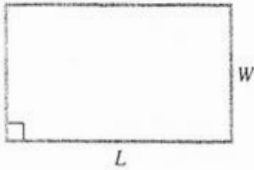
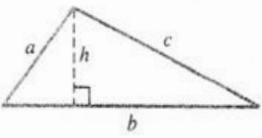
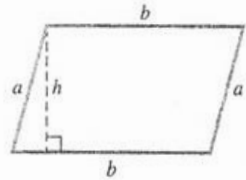
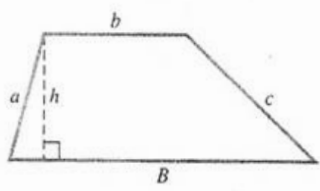
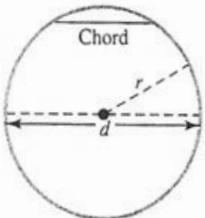

# Formulas

Figure	Formulas	Illustration
Square	Perimeter: $P = 4s$ Area: $A = s^2$	
Rectangle	Perimeter: $P = 2L + 2W$ Area: $A = LW$	
Triangle	Perimeter: $P = a + b + c$ Area: $A = \frac{1}{2}bh$	
Parallelogram	Perimeter: $P = 2a + 2b$ Area: $A = bh$	
Trapezoid	Perimeter: $P = a + b + c + B$ Area: $A = \frac{1}{2}h(b + B)$	
Circle	Diameter: $d = 2r$ Circumference: $C = 2\pi r$ $C = \pi d$ Area: $A = \pi r^2$	

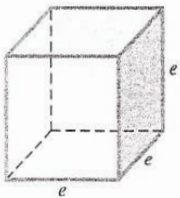
# Formulas

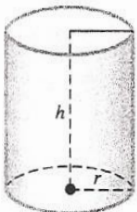
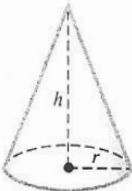
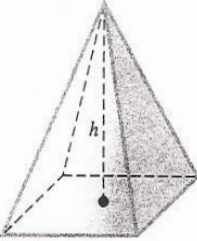
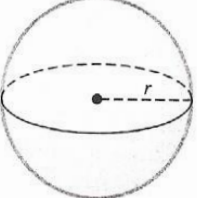
Figure	Formulas	Illustration
Cube	Volume: $V = e^3$ Surface area: $S = 6e^2$	
Rectangular Solid	Volume: $V = LWH$ Surface area: $A = 2HW + 2LW + 2LH$	
Right Circular Cylinder	Volume: $V = \pi r^2 h$ Surface area: $S = 2\pi r h + 2\pi r^2$ (Includes both circular bases)	
Cone	Volume: $V = \frac{1}{3} \pi r^2 h$ Surface area: $S = \pi r \sqrt{r^2 + h^2} + \pi r^2$ (Includes circular base)	
Right Pyramid	Volume: $V = \frac{1}{3} Bh$ $B =$ area of the base	
Sphere	Volume: $V = \frac{4}{3} \pi r^3$ Surface area: $S = 4\pi r^2$	

## Other Formulas

**Distance:**  $d = rt$ ;  $r =$  rate or speed,  $t =$  time

**Percent:**  $p = br$ ;  $p =$  percentage,  $b =$  base,  $r =$  rate

**Temperature:**  $F = \frac{9}{5}C + 32$      $C = \frac{5}{9}(F - 32)$

**Simple Interest:**  $I = prt$ ;  $p =$  principal or amount invested,  $r =$  rate or percent,  $t =$  time in years