

# Math 1010 - Intermediate Algebra

## Practice Problems for the Midterm Exam

An equation that defines  $y$  as a function of  $x$  is given. Solve for  $y$  in terms of  $x$ , and replace  $y$  with the function notation  $f(x)$ .

1)  $5x - 6y = 5$

A)  $f(x) = \frac{5 - 5x}{-6}$

B)  $f(x) = -5x - \frac{5}{6}$

C)  $f(x) = 5 - 5x$

D)  $f(x) = 5 - \frac{5x}{6}$

1) \_\_\_\_\_

Graph the compound inequality.

2)  $2x - y > 4$  and  $x \leq 4$

2) \_\_\_\_\_

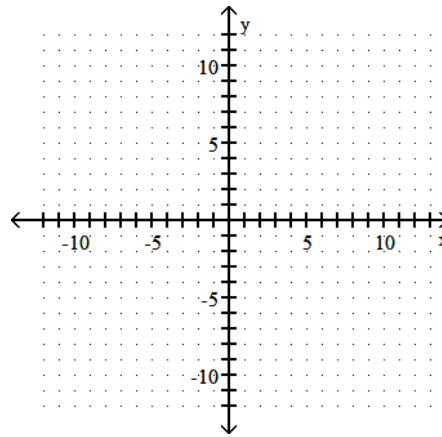

Solve the equation or inequality.

3)  $|7x - 7| - 5 < -7$

A)  $\left(-\infty, \frac{9}{7}\right)$

B)  $\left(\frac{5}{7}, \frac{9}{7}\right)$

C)  $\emptyset$

D)  $\left(-\infty, \frac{5}{7}\right)$

3) \_\_\_\_\_

Perform the indicated operations.

4)  $\left(-\frac{7}{6} - \frac{1}{3}\right) - \left(-\frac{1}{3}\right)$

A)  $-\frac{7}{3}$

B)  $-\frac{7}{6}$

C)  $-7$

D)  $\frac{7}{6}$

4) \_\_\_\_\_

Solve the system by substitution or elimination.

$4x + 5y + z = 11$

5)  $3x - 5y - z = -18$

$3x + y + 2z = -9$

A)  $\{(-1, -5, 4)\}$

B)  $\{(-5, 4, -1)\}$

C)  $\{(-1, 4, -5)\}$

D)  $\emptyset$

5) \_\_\_\_\_

Perform the indicated operations.

6)  $-11 - (11 - 14) - 15$

A)  $-21$

B)  $7$

C)  $-51$

D)  $-23$

6) \_\_\_\_\_

Solve the problem.

7) From a point on a river, two boats are driven in opposite directions, one at 8 miles per hour and the other at 12 miles per hour. In how many hours will they be 80 miles apart? (Hint: Use a chart and the formula  $d=rt$ )

- A) 5 hours                      B) 1 hour                      C) 6 hours                      D) 4 hours

7) \_\_\_\_\_

Perform the indicated operations.

8)  $\frac{24x^3 + 24x^2 + 20x + 3}{4x}$

A)  $6x^3 + 6x^2 + 5x + \frac{3}{4}$

B)  $6x^2 + 6x + 5 + \frac{3}{4x}$

C)  $6x^2 + 6x + 5 + \frac{3}{x}$

D)  $6x^2 + 24x + 20 + \frac{3}{x}$

8) \_\_\_\_\_

Solve the system by graphing. Express your answer as an ordered pair. (3 pts)

9)  $x - y = 6$   
 $x + y = 8$

9) \_\_\_\_\_

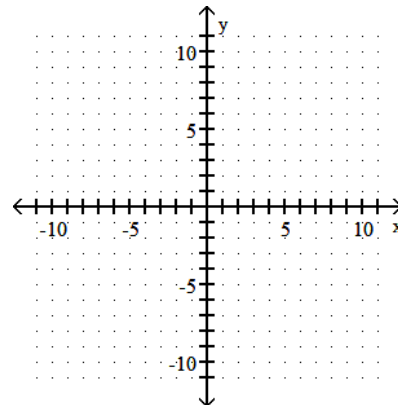

Perform the indicated operations.

10)  $(2x - 7y)^2$

A)  $2x^2 + 49y^2$

B)  $2x^2 - 28xy + 49y^2$

C)  $4x^2 + 49y^2$

D)  $4x^2 - 28xy + 49y^2$

10) \_\_\_\_\_

Solve the problem.

11) Find the measures of the supplementary angles.

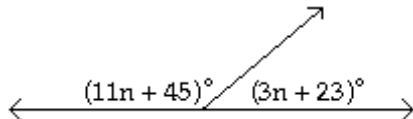

A)  $47^\circ, 43^\circ$

B)  $43^\circ, 47^\circ$

C)  $137^\circ, 43^\circ$

D)  $133^\circ, 47^\circ$

11) \_\_\_\_\_

Simplify. Write the answer with only positive exponents. Assume that all variables represent nonzero real numbers.

12)  $\left(\frac{9x^2}{y^3}\right)^3 \left(\frac{15x^2}{y^{-4}}\right)^{-2}$  12) \_\_\_\_\_

A)  $\frac{25x^3}{9y^{17}}$       B)  $\frac{81x^2}{25y^{17}}$       C)  $-\frac{27x}{25y^{13}}$       D)  $\frac{81x^2 y^{17}}{5}$

Perform the indicated operations.

13)  $(2x^3 - 5x^2 - 10x - 4) \div (x - 4)$  13) \_\_\_\_\_

A)  $2x^2 - x + 4 + \frac{3}{x - 4}$       B)  $2x^2 + 3x + 2$

C)  $2x^3 + 3x + \frac{4}{x - 4}$       D)  $2x^2 + 3x + 2 + \frac{4}{x - 4}$

Simplify. Write the answer with only positive exponents. Assume that all variables represent nonzero real numbers.

14)  $(2x^5 y^4)^2 (5y^2)^3$  14) \_\_\_\_\_

A)  $500x^{10}y^{14}$       B)  $500x^7y^{11}$       C)  $10x^5y^6$       D)  $10x^{10}y^{14}$

Solve the problem.

15) Find  $f(-4)$  when  $f(x) = -x^2 + 3x + 4$ . 15) \_\_\_\_\_

A) 32      B) -24      C) 0      D) 8

Solve the system by substitution or elimination. If a system is inconsistent or has dependent equations, say so.

16)  $x + 3y = -9$  16) \_\_\_\_\_  
 $-3x + 2y = 16$

A)  $\{(-6, -1)\}$       B)  $\{(6, 0)\}$   
C)  $\{(-7, 0)\}$       D)  $\emptyset$ ; inconsistent system

Solve the problem.

17) The perimeter of a rectangle is 44 cm. The length is 10 cm longer than the width. What are the length and width of the rectangle? (Hint: Use  $P = 2L + 2W$ ) 17) \_\_\_\_\_

A) Length: 22 cm; width: 12 cm      B) Length: 19 cm; width: 9 cm  
C) Length: 16 cm; width: 6 cm      D) Length: 10 cm; width: 6 cm

Solve the problem.

18) Find  $f(-3)$  when  $f(x) = 2x^2 - 2x - 5$ . 18) \_\_\_\_\_

A) 7      B) 10      C) 19      D) 29

Solve the problem.

19) A ball is projected upward from ground level. After  $t$  seconds, its height in feet is a function defined by  $f(t) = -16t^2 + 112t$ . After how many seconds will it reach a height of 192 ft? 19) \_\_\_\_\_

A) 3 sec      B) 3.5 sec and 4.5 sec  
C) The ball never reaches a height of 192 feet.      D) 3 sec and 4 sec

Solve the absolute value inequality.

20)  $|2 - 3x| \geq 8$

A)  $(-\infty, -2] \cup [\frac{10}{3}, \infty)$

C)  $[\frac{10}{3}, \infty)$

B)  $(-\infty, -\frac{10}{3}] \cup [8, \infty)$

D)  $[-2, \frac{10}{3}]$

20) \_\_\_\_\_

Solve the equation. Then tell whether the equation is a conditional equation, an identity, or a contradiction.

21)  $3x - (6 - x) + 2x + 6 = 6x + 3$

A)  $(-\infty, \infty)$ ; identity

C)  $\{3\}$ ; conditional equation

B)  $\{15\}$ ; conditional equation

D)  $\emptyset$ ; contradiction

21) \_\_\_\_\_

For the given pair of functions, find the requested function.

22)  $f(x) = x^2 + 4$  and  $g(x) = 2x + 7$ ;  $(g \circ f)(5)$ .

A) 293

B) 51

C) 65

D) 36

22) \_\_\_\_\_

Solve the problem.

23) Jim has gotten scores of 98 and 76 on his first two tests. What score must he get on his third test to keep an average of 80 or greater?

A) At least 66

B) At least 87

C) At least 65

D) At least 84.7

23) \_\_\_\_\_

Factor out the greatest common factor. Simplify the factors, if possible.

24)  $30x^8y^9 - 24x^4y^6 - 12x^6y^2$

A)  $6x^4(5x^4y^9 - 4y^6 - 2x^2y^2)$

C)  $x^4y^2(30x^4y^7 - 24y^4 - 12x^2)$

B)  $6x^4y^2(5x^4y^7 - 4y^4 - 2x^2)$

D)  $6(5x^8y^9 - 4x^4y^6 - 2x^6y^2)$

24) \_\_\_\_\_

Solve the compound value inequality.

25)  $-4x \leq -12$  or  $9x - 6 < 3x$

A)  $\emptyset$

B)  $(-\infty, 1) \cup [3, \infty)$

C)  $[1, 3]$

D)  $(1, 3)$

25) \_\_\_\_\_

Evaluate the expression.

26)  $(-10)^0$

A) 1

B) 0

C) -1

D) -10

26) \_\_\_\_\_

For the given pair of functions, find the requested function.

27) If  $f(x) = x^2 - x - 7$  and  $g(x) = x - 1$ , find  $(fg)(x)$ .

A)  $x^3 - 2x^2 - 7x + 7$

C)  $x^3 - 2x^2 - 6x + 7$

B)  $x^3 - 2x^2 - 8x - 7$

D)  $x^3 - 6x + 7$

27) \_\_\_\_\_

Solve the equation.

28)  $\frac{-6x + 5}{3} + 1 = -\frac{5x}{6}$

A)  $\left\{\frac{16}{17}\right\}$

B)  $\left\{-\frac{4}{7}\right\}$

C)  $\left\{\frac{4}{7}\right\}$

D)  $\left\{\frac{16}{7}\right\}$

28) \_\_\_\_\_

Solve the inequality. Give the solution set in both interval and graph forms.

29)  $-3(6a - 9) < -21a + 18$

29) \_\_\_\_\_

A)  $(-21, \infty)$

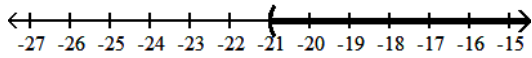

B)  $(-3, \infty)$

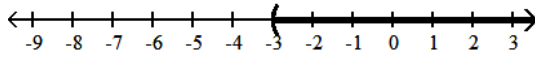

C)  $(-\infty, -3)$

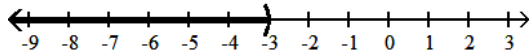

D)  $(-\infty, -21)$

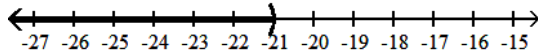

For the given pair of functions, find the requested function.

30)  $f(x) = 2x^2 + 2x - 5$  and  $g(x) = x - 1$ ;  $(f \circ g)(x)$ .

30) \_\_\_\_\_

A)  $-2x^2 + 2x - 5$

B)  $2x^2 - 8x - 1$

C)  $2x^2 - 2x - 1$

D)  $2x^2 - 2x - 5$

Solve the equation.

31)  $-6x + 5(-2x - 3) = -24 - 7x$

31) \_\_\_\_\_

A)  $\{1\}$

B)  $\left\{\frac{39}{23}\right\}$

C)  $\{-1\}$

D)  $\left\{\frac{13}{3}\right\}$

Graph the linear function. What is its domain and range?

32)  $f(x) = \frac{1}{2}x - 4$

32) \_\_\_\_\_

Domain: \_\_\_\_\_

Range: \_\_\_\_\_

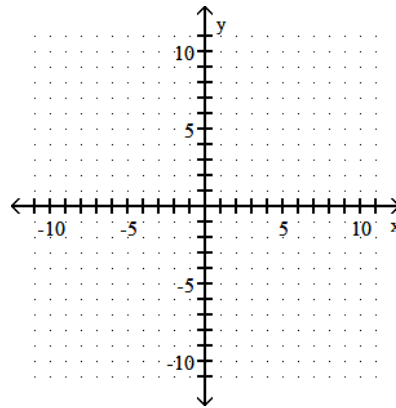

Factor.

33)  $8x + ay + ax + 8y$

- A)  $8(x + y) + a(x + y)$   
 C)  $(x + y)(8 + a)$

- B)  $8a(x + y)$   
 D) cannot be factored

33) \_\_\_\_\_

Solve the inequality. Give the solution set in both interval and graph forms.

34)  $1 < 2y + 3 \leq 9$

A)  $[-1, 3]$

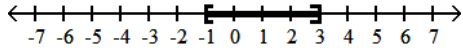

B)  $(-1, 3)$

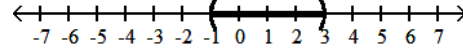

C)  $(-1, 3]$

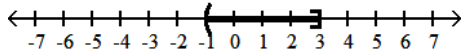

D)  $[-1, 3)$

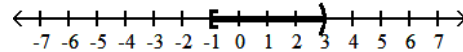

34) \_\_\_\_\_

For the given pair of functions, find the requested function.

35)  $f(x) = 10x^2 + 12x + 11$  and  $g(x) = 13x^2 + 20x - 8$ ;  $(f - g)(x)$

- A)  $-3x^2 - 8x + 19$       B)  $-3x^2 - 8x + 3$       C)  $-3x^4 - 8x^2 + 19$       D)  $-3x^2 + 8x - 19$

35) \_\_\_\_\_

Evaluate the expression.

36)  $-6^2$

- A) -36      B) 36      C) -64      D) -12

36) \_\_\_\_\_

Solve the equation.

37)  $7m(m - 7) = 3(7 - m)$

- A)  $\left\{-\frac{3}{7}, 7\right\}$       B)  $\left\{\frac{3}{7}\right\}$       C)  $\{0, -4\}$       D)  $\left\{\frac{7}{3}, 7\right\}$

37) \_\_\_\_\_

Decide whether the relation is a function, and give the domain and range.

38)

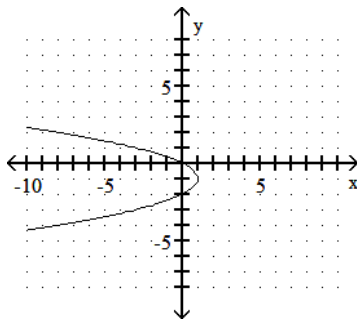

- A) Not a function; domain:  $(-\infty, 1]$ ; range:  $(-\infty, \infty)$   
 B) Function; domain:  $(-\infty, 1]$ ; range:  $(-\infty, \infty)$

38) \_\_\_\_\_

Solve the problem involving consecutive integers.

39) If three times the smaller of two consecutive integers is added to four times the larger, the result is 123. Find the smaller integer.

- A) 16      B) 51      C) 17      D) 18

39) \_\_\_\_\_

Evaluate the expression.

40)  $10^{-1} - 4^{-1}$

A)  $-\frac{1}{6}$

B)  $-\frac{20}{3}$

C)  $\frac{3}{20}$

D)  $-\frac{3}{20}$

40) \_\_\_\_\_

Write the number in standard form.

41)  $4.72 \times 10^{-4}$

A) 0.0000472

B) 0.00472

C) 0.000472

D) -472,000

41) \_\_\_\_\_

Write an equation for the line. Give the final answer in slope-intercept form.

42) Through  $(-6, -9)$  and  $(3, 8)$

A)  $y = -\frac{17}{9}x + \frac{7}{3}$

B)  $y = \frac{17}{9}x + \frac{7}{3}$

C)  $y = -\frac{3}{5}x + \frac{49}{5}$

D)  $y = \frac{3}{5}x + \frac{49}{5}$

42) \_\_\_\_\_

Write an equation of the line through the given point with the given slope. Write the equation in slope-intercept form.

43)  $(4, 2); m = -3$

A)  $y = -\frac{1}{3}x + 14$

B)  $y = -3x + \frac{1}{14}$

C)  $y = -3x + 14$

D)  $y = -3x - 14$

43) \_\_\_\_\_

Solve the problem using a system of equations.

44) Paul invested four times as much money in an account paying 4% interest than he did in an account paying 3% interest. If the total interest paid was \$475, how much did he invest in each? (Hint: Use  $I = Prt$ )

44) \_\_\_\_\_

A) \$10,000 at 4%, \$3000 at 3%

B) \$10,000 at 4%, \$2500 at 3%

C) \$2500 at 4%, \$10,000 at 3%

D) \$100 at 4%, \$25 at 3%

Find the midpoint of the segment with the given endpoints.

45)  $(2, -9)$  and  $(-5, 3)$

A)  $(-3, -6)$

B)  $(-\frac{3}{2}, -3)$

C)  $(\frac{7}{2}, -6)$

D)  $(7, -12)$

45) \_\_\_\_\_

Solve the problem.

46) Find  $f(k - 1)$  when  $f(x) = 2x^2 - 4x - 4$ .

A)  $2k^2 - 12k - 6$

B)  $2k^2 - 8k - 6$

C)  $-8k^2 + 2k + 2$

D)  $2k^2 - 8k + 2$

46) \_\_\_\_\_

Simplify the expression.

47)  $3(2m + 3) - 3(5m - 5)$

A)  $7m + 24$

B)  $-9m + 24$

C)  $-9m - 6$

D)  $-9m - 2$

47) \_\_\_\_\_

Find the slope of the line.

48)  $5x - 4y = 14$

A)  $-\frac{7}{2}$

B)  $-\frac{4}{5}$

C)  $\frac{5}{4}$

D)  $-\frac{5}{4}$

48) \_\_\_\_\_

Factor the polynomial completely.

49)  $125a^3 - 27b^3$

A)  $(125a - 3b)(a^2 + 15ab + 9b^2)$

C)  $(5a - 3b)(25a^2 + 9b^2)$

B)  $(5a - 3b)(25a^2 + 15ab + 9b^2)$

D)  $(5a + 3b)(25a^2 - 15ab + 9b^2)$

49) \_\_\_\_\_

Factor the trinomial completely.

50)  $-x^2 + 7x + 18$

A)  $-(x + 9)(x + 2)$

B)  $-(x + 9)(x - 2)$

C)  $-(x - 9)(x - 2)$

D)  $-(x - 9)(x + 2)$

50) \_\_\_\_\_

Find the slope of the line.

51)  $x = -10$

A) -10

B) 1

C) 0

D) Undefined

51) \_\_\_\_\_

Decide whether or not the ordered pair is a solution of the system.

52)  $(1, 4)$

$3x + y = 7$

$2x + 3y = 14$

A) Yes

B) No

52) \_\_\_\_\_

Add or subtract as indicated.

53)  $-12 - 17$

A) 29

B) 5

C) -5

D) -29

53) \_\_\_\_\_

Factor the trinomial completely.

54)  $5x^3 + 10x^2 - 40x$

A)  $5x(x + 2)(x - 4)$

C)  $(5x^2 + 10x)(x - 4)$

B)  $5x(x - 2)(x + 4)$

D)  $(x - 2)(5x^2 + 20)$

54) \_\_\_\_\_

Evaluate the function.

55) The graph of  $y = f(x)$  is shown below. Find  $f(-1)$

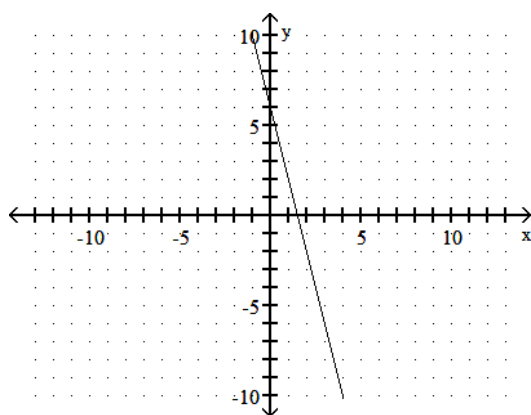

A) 10

B) 2

C) -2

D) 6

55) \_\_\_\_\_

Use the order of operations to simplify the expression.

56)  $(-8)(\sqrt{64}) - (-2)(-10)$

A) 20

B) -64

C) -84

D) -44

56) \_\_\_\_\_

Solve the absolute value equation.

57)  $|4k + 5| + 8 = 12$

A)  $\emptyset$

B)  $(-\infty, \infty)$

C)  $\left\{-4, -\frac{4}{9}\right\}$

D)  $\left\{-\frac{9}{4}, -\frac{1}{4}\right\}$

57) \_\_\_\_\_

Evaluate the function.

58) Find  $f(-5)$ .

x	y = f(x)
4	1
1	-2
-2	-5
-5	-8
-8	-11

A) -8

B) 8

C) -2

D) -5

58) \_\_\_\_\_

Find the square root. If it is not a real number, say so.

59)  $-\sqrt{64}$

A) 8

C) -8

B) 16

D) Not a real number

59) \_\_\_\_\_

Find all solutions by factoring.

60)  $-5b^2 + 45 = 0$

A) No real solution

B)  $\{0, 3\}$

C)  $\{-3, 3\}$

D)  $\{-5, 3\}$

60) \_\_\_\_\_

Use scientific notation to simplify. Write the answer in both scientific notation and standard notation.

61)  $\frac{81,000 \times 0.004}{0.09 \times 900,000}$

A)  $4 \times 10^{-1}; 0.4$

B)  $0.4 \times 10^{-2}; 0.04$

C)  $4 \times 10^{-3}; 0.004$

D)  $4 \times 10^{-2}; 0.04$

61) \_\_\_\_\_

Solve the mixture problem.

62) How many liters of a 30% alcohol solution must be mixed with 20 liters of a 50% solution to get a 40% solution? (Hint: Use a chart and the fact that the number of liters  $\times$  percent = liters of pure alcohol.)

A) 40 liters

B) 2 liters

C) 4 liters

D) 20 liters

62) \_\_\_\_\_

Find the slope of the line going through the given pair of points.

63)  $(-7, -8)$  and  $(1, 8)$

A) 2

B) -7

C)  $\frac{1}{2}$

D)  $-\frac{1}{7}$

63) \_\_\_\_\_

Solve the problem.

64) Find the length of a rectangular lot with a perimeter of 92 m if the length is 6 m more than the width. (Hint: Draw a picture and use the formula:  $P = 2L + 2W$ )

A) 52 m

B) 46 m

C) 26 m

D) 20 m

64) \_\_\_\_\_

Find all solutions by factoring.

65)  $x^2 + 4x - 21 = 0$

A)  $\{3, 7\}$

B)  $\{-3, 7\}$

C)  $\{-7, 3\}$

D)  $\{-7, -3\}$

65) \_\_\_\_\_

Graph the linear inequality.

66)  $5x + y \leq 2$

66) \_\_\_\_\_

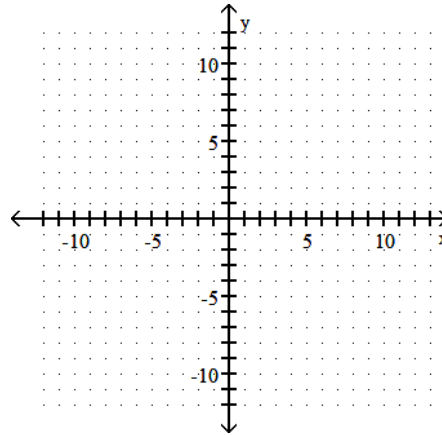

Perform the indicated operation.

67)  $\frac{1}{8} \left( -\frac{9}{8} \right)$

A)  $\frac{9}{64}$

B)  $-\frac{5}{4}$

C)  $-\frac{9}{64}$

D)  $\frac{5}{4}$

67) \_\_\_\_\_

Factor the polynomial completely.

68)  $36x^2 + 49$

A)  $(6x + 7)^2$

B)  $(6x - 7)^2$

C) Prime

D)  $(6x + 7)(6x - 7)$

68) \_\_\_\_\_

Solve.

69)  $-9y^2 + wy - x = 0$  for  $w$

A)  $w = \frac{9y^2 + y}{x}$

B)  $w = \frac{x - 9y^2}{y}$

C)  $w = \frac{x + 9y^2}{y}$

D)  $w = -\frac{x + 9y^2}{y}$

69) \_\_\_\_\_

Evaluate the expression for  $a = -5$ ,  $b = 16$  and  $c = 7$ .

70)  $\frac{2c - a^2}{9a + c^2}$

A)  $-\frac{11}{4}$

B)  $\frac{39}{4}$

C)  $\frac{11}{94}$

D)  $-\frac{11}{94}$

70) \_\_\_\_\_

Solve the problem.

71) A woman has \$1.70 in dimes and nickels. She has 2 more dimes than nickels. How many nickels does she have? (Hint: Use a chart and the fact that the number of coins  $\times$  value = total value.)

A) 8

B) 12

C) 14

D) 10

71) \_\_\_\_\_

Provide an appropriate response.

72) Which one of the following is the graph of a function?

72) \_\_\_\_\_

A)

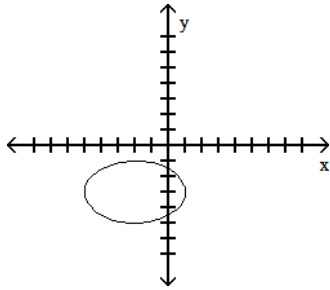

B)

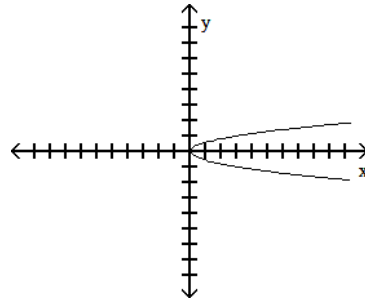

C)

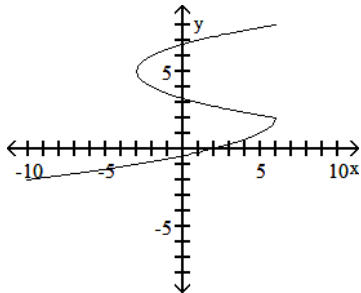

D)

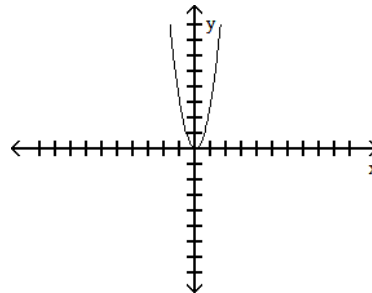

Factor each polynomial completely.

73)  $30x^3 - 28x^2 - 16x$

73) \_\_\_\_\_

A)  $x(3x + 4)(3x - 4)$

B)  $2(5x^2 + 2)(3x - 4)$

C)  $2x(5x + 2)(3x - 4)$

D)  $x(5x + 2)(6x - 8)$

Solve the system by substitution. If the system is inconsistent or has dependent equations, say so.

74)  $x + y = 7$

74) \_\_\_\_\_

$8x + 8y = 56$

A)  $\{(0, 0)\}$

B)  $\{(6, 1)\}$

C)  $\emptyset$ ; inconsistent system

D)  $\{(x, y) \mid x + y = 7\}$ ; dependent equations

Decide whether the pair of lines is parallel, perpendicular, or neither.

75)  $2x + 3y = -5$  and  $2y = 3x + 4$

75) \_\_\_\_\_

A) Parallel

B) Perpendicular

C) Neither

Solve the investment problem.

76) Mardi received an inheritance of \$70,000. She invested part at 7% and deposited the remainder in tax-free bonds at 8%. Her total annual income from the investments was \$5200. Find the amount invested at 7%. (Hint: Use a chart and the formula:  $I = Prt$ .)

76) \_\_\_\_\_

A) \$40,000

B) \$39,000

C) \$64,800

D) \$20,000

Graph the function.

77)  $f(x) = x^2 - 2x - 8$

77) \_\_\_\_\_

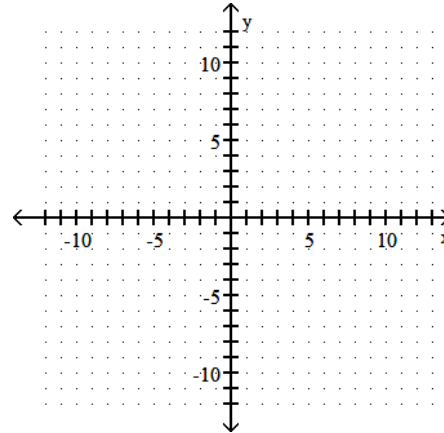

Simplify. Write the answer with only positive exponents. Assume that all variables represent nonzero real numbers.

78)  $(2p^3q^5)^{-2}(4p^5q^3)^2$

78) \_\_\_\_\_

A)  $\frac{4p^4}{q^4}$

B)  $\frac{4p^4}{q^{-4}}$

C)  $\frac{4q^4}{p^{-4}}$

D)  $\frac{p^4}{4q^{-4}}$

Solve the compound inequality.

79)  $-23 \leq 3x - 8$  and  $9x - 8 < -17$

79) \_\_\_\_\_

A)  $(-5, -1)$

B)  $[-5, -1]$

C)  $[-5, -1)$

D)  $(-5, -1]$

Solve the problem.

80) Students at East Central High School earned \$628 selling car washes. They want to make \$3420 for a club trip. What percent of their goal has been reached? Round to the nearest tenth of a percent, if necessary.

80) \_\_\_\_\_

A) 5.4%

B) 18.4%

C) 54%

D) 1.8%